

Single impeller centrifugal pumps manufactured cast iron, suitable for pressure boosting of water for irrigation, and non-aggressive liquids for civil and industrial uses.

CMR series is fitted with an open impeller for suspended solids handling.



SPECIFICATIONS

- Maximum working pressure: 6 bar, 8 bar for CMA 1.50-2.00-3.00 – CMB 4.40-5.50
- Maximum liquid temperature: 35°C according EN 60335-2-41 for domestic uses 40°C for CMA 0.50-0.75-0.80-1.00 90°C for other models

MATERIALS

- Pump body in cast iron
- Mechanical seal in carbon/ceramic/NBR
- Impeller: - in tecnopolymer for CMA 0.50-0.75-0.80-1.00 - in brass for CMA 1.50-2.00-3.00 CMB 2.00-3.00-4.00-5.50 CMR 0.75-1.00 - in cast iron for the other models.
- Shaft: - in AISI 303 for CMA 0.75-0.80-1.00 1.50-2.00-3.00 CMB 1.50-2.00-3.00 CMD 1.50-2.00-3.00 - in AISI 304 for CMB 4.00-5.50 CMD 4.00 - in AISI 416 for CMA 0.50
- Bracket: - in alluminium for CMA 0.50-0.75-0.80-1.00 CMB 0.75-1.00 CMC 0.75-1.00 CMR 0.75-1.00 - in cast iron for the other models

TECHNICAL DATA

- T.E.F.C. 2 poles motor
- Insulation class F
- Protection degree IP44
- 1~230V ± 10% 50Hz, 3~230/400V ± 10% 50Hz
- Permanent split capacitor and automatic thermal overload protection for single-phase version
- Thermal protection to be provided by the user for three-phase version

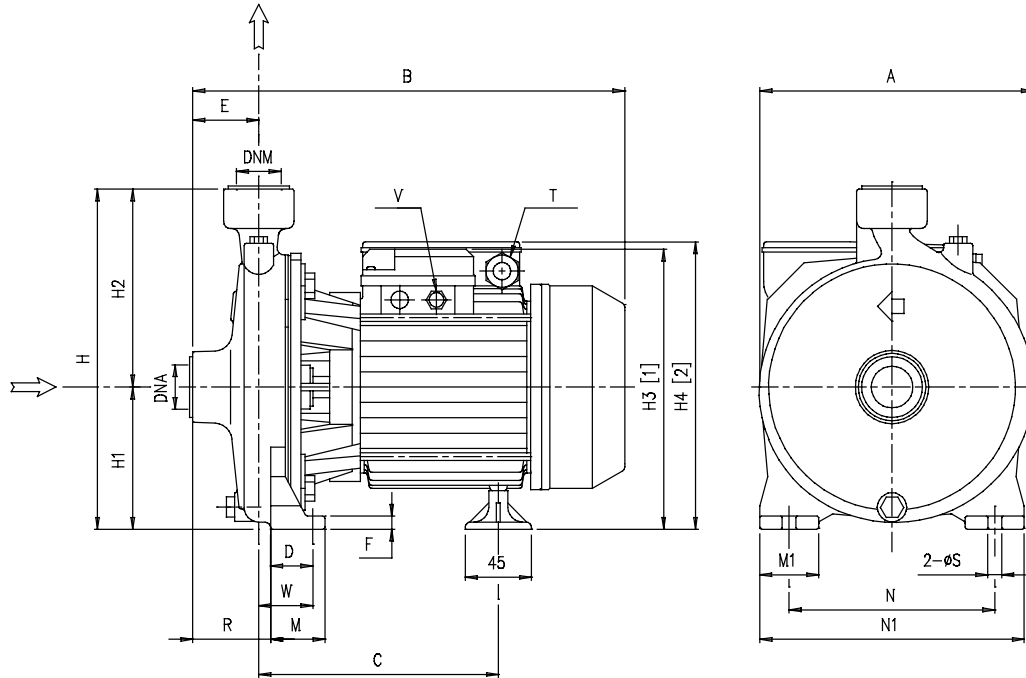

DIMENSIONAL TABLE

Pump type		Dimensions (mm)																				Weight kg		
		A	B	C	D	E	F	H	H1	H2	H3	H4	M	M1	N	N1	R	T	V	W	S		DNA	DNM
Single-phase	Three-phase										3-	1-						1-	3-					
CMA 0.50 M	CMA 0.50 T	160	261,8	158,8	30	44	8	202	82	120	172,5	173	40	40	110	150	44	PG11	PG11	30	9,5	G 1	G 1	7,3
CMA 0.75 M	CMA 0.75 T	185	300,3	171,8	36,8	45	9	232	97	135	197,5	198	45	40	140	180	45	PG11	PG11	36,8	9,5	G 1	G 1	11,7
CMA 0.80 M	CMA 0.80 T	185	300,3	171,8	36,8	45	9	232	97	135	197,5	198	45	40	140	180	45	PG11	PG11	36,8	9,5	G 1	G 1	10,7
CMA 1.00 M	CMA 1.00 T	185	300,3	171,8	36,8	45	9	232	97	135	197,5	198	45	40	140	180	45	PG11	PG11	36,8	9,5	G 1	G 1	12,0
CMA 1.50 M	CMA 1.50 T	200	347,3	208,3	41,8	45,5	9	252	100	152	214	232	50	40	155	194	45,5	PG13,5	PG11	41,8	9,5	G 1 1/4	G 1	19,4
CMA 2.00 M	CMA 2.00 T	225	360,3	208,3	41,8	45,5	9	285	115	170	229	247	50	40	180	220	45,5	PG13,5	PG11	41,8	9,5	G 1 1/4	G 1	21,3
-	CMA 3.00 T	225	360,3	208,3	41,8	45,5	9	285	115	170	229	-	50	40	180	220	45,5	-	PG11	41,8	9,5	G 1 1/4	G 1	22,0
CMB 0.75 M	CMB 0.75 T	188	315,3	182,3	36,8	49,5	9	251,5	101,5	150	127	127,5	45	40	140	180	65,5	PG11	PG11	52,8	9,5	G 2	G 1 1/4	12,5
CMB 1.00 M	CMB 1.00 T	188	315,3	182,3	36,8	49,5	9	251,5	101,5	150	127	127,5	45	40	140	180	65,5	PG11	PG11	52,8	9,5	G 2	G 1 1/4	13,8
CMB 1.50 M	CMB 1.50 T	188	349,3	206,3	36,8	49,5	9	251,5	101,5	150	215,5	233,5	45	40	140	180	65,5	PG13,5	PG11	52,8	9,5	G 2	G 1 1/4	20,5
CMB 2.00 M	CMB 2.00 T	200	373,3	209,3	36,8	57,5	9	271,5	111,5	160	225,5	243,5	45	40	160	200	76,5	PG13,5	PG11	55,8	9,5	G 2	G 1 1/4	21,5
-	CMB 3.00 T	200	373,3	209,3	36,8	57,5	9	271,5	111,5	160	225,5	-	45	40	160	200	76,5	-	PG11	55,8	9,5	G 2	G 1 1/4	21,5
-	CMB 4.00 T	247	428,8	222,3	48	60	12	323,5	133,5	190	264,5	-	60	50	190	240	77,5	-	G 1/2	65,5	12	G 2	G 1 1/4	39,0
-	CMB 5.50 T	247	428,8	222,3	48	60	12	323,5	133,5	190	264,5	-	60	50	190	240	77,5	-	G 1/2	65,5	12	G 2	G 1 1/4	41,0
CMC 0.75 M	CMC 0.75 T	186	313,3	186,8	36,8	43	9	247	97	150	197,5	198	45	40	140	180	63,5	PG11	PG11	57,3	9,5	G 2	G 2	12,3
CMC 1.00 M	CMC 1.00 T	186	313,3	186,8	36,8	43	9	247	97	150	197,5	198	45	40	140	180	63,5	PG11	PG11	57,3	9,5	G 2	G 2	13,0
CMD 1.50 M	CMD 1.50 T	213	384,3	222,8	36,8	68	12	271,5	111,5	160	225,5	243,5	45	40	160	200	100,5	PG13,5	PG11	69,3	9,5	G 2 1/2	G 2 1/2	22,0
CMD 2.00 M	CMD 2.00 T	213	397,3	222,8	36,8	68	12	271,5	111,5	160	225,5	243,5	45	40	160	200	100,5	PG13,5	PG11	69,3	9,5	G 2 1/2	G 2 1/2	24,0
-	CMD 3.00 T	213	397,3	222,8	36,8	68	12	271,5	111,5	160	225,5	-	45	40	160	200	100,5	-	PG11	69,3	9,5	G 2 1/2	G 2 1/2	24,0
-	CMD 4.00 T	213	449,3	234,8	36,8	68	12	271,5	111,5	160	354	-	45	50	160	200	100,5	-	G 1/2	69,3	9,5	G 2 1/2	G 2 1/2	31,5
CMR 0.75 M	CMR 0.75 T	180	310,3	181,8	36,8	45	9	229	97	132	197,5	198	45	40	140	180	60,5	PG11	PG11	52,3	9,5	G 1 1/2	G 1 1/2	11,0
CMR 1.00 M	CMR 1.00 T	180	310,3	181,8	36,8	45	9	229	97	132	197,5	198	45	40	140	180	60,5	PG11	PG11	52,3	9,5	G 1 1/2	G 1 1/2	12,2

PERFORMANCE CURVES (according to ISO 9906 Annex A)

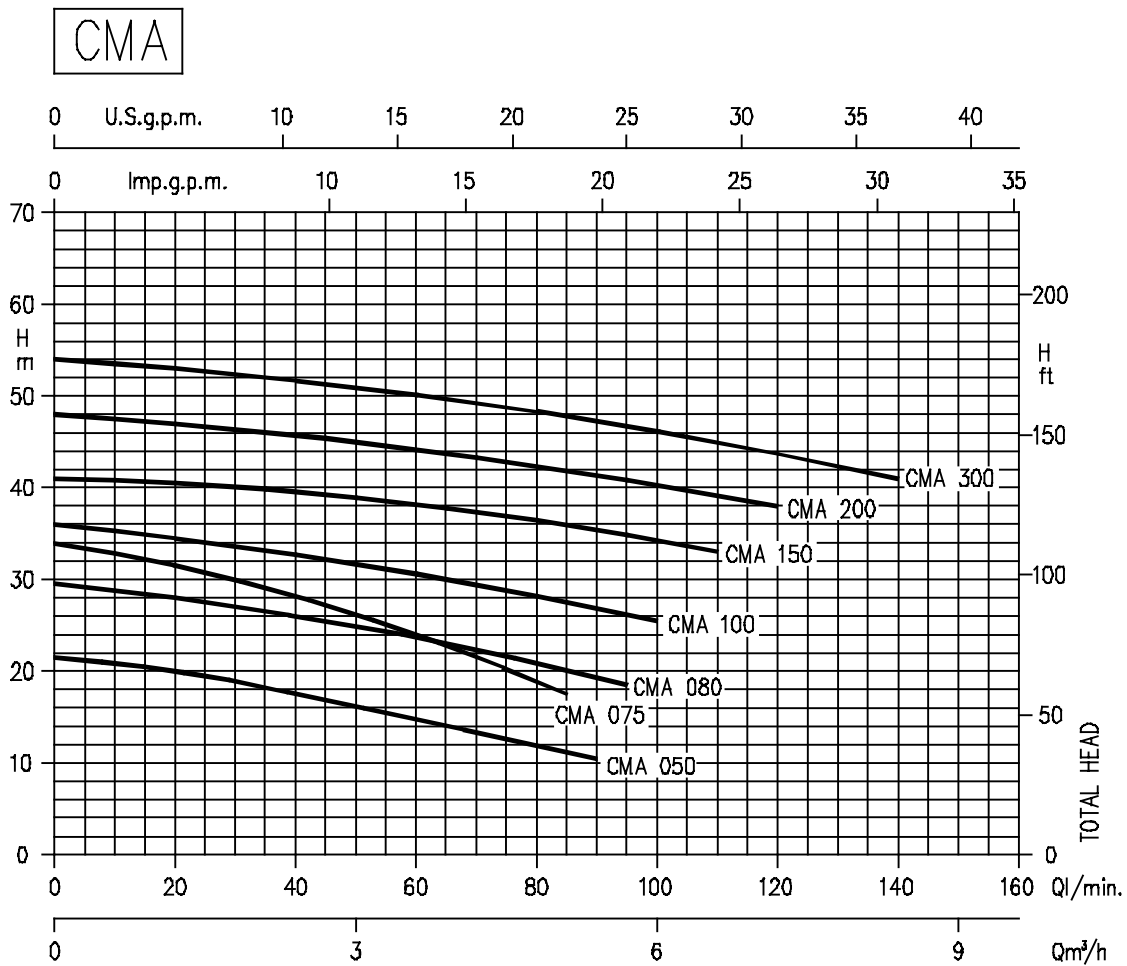

PERFORMANCE TABLE

Pump type		kW	Capacitor		Absorbed Current (A)			l/min m³/h	Q=Capacity											
Single-phase 230V 50Hz	Three-phase 230/400V 50Hz		µF	Vc	Single-phase	Three-phase 230V 400V			20	40	60	80	85	90	95	100	110	120	140	
								H=Total head												
CMA 0.50 M	CMA 0.50 T	0,37	10	450	3,2	2,4	1,4	20	17,8	15	12,1	11,2	10,5	-	-	-	-	-		
CMA 0.75 M	CMA 0.75 T	0,55	16	450	4,7	3,2	1,8	31,5	28,2	24	18,9	17,5	-	-	-	-	-	-		
CMA 0.80 M	CMA 0.80 T	0,6	16	450	4,8	3,3	1,9	28	26,1	23,8	20,9	20,1	19,3	18,5	-	-	-	-		
CMA 1.00 M	CMA 1.00 T	0,75	20	450	6,2	4,3	2,5	34,5	32,8	30,6	28,2	27,6	26,9	26,2	25,5	-	-	-		
CMA 1.50 M	CMA 1.50 T	1,1	35	450	8	5,4	3,1	40,5	39,6	38,2	36,5	36	35,6	34,9	34,3	33	-	-		
CMA 2.00 M	CMA 2.00 T	1,5	40	450	10,3	7,5	4,3	47	45,8	44,2	42,4	41,9	41,4	40,9	40,3	39,2	38	-		
-	CMA 3.00 T	2,2	-	-	-	9,5	5,5	53	51,8	50,2	48,3	47,8	47,3	46,7	46,2	45	43,7	41		

PERFORMANCE CURVES (according to ISO 9906 Annex A)

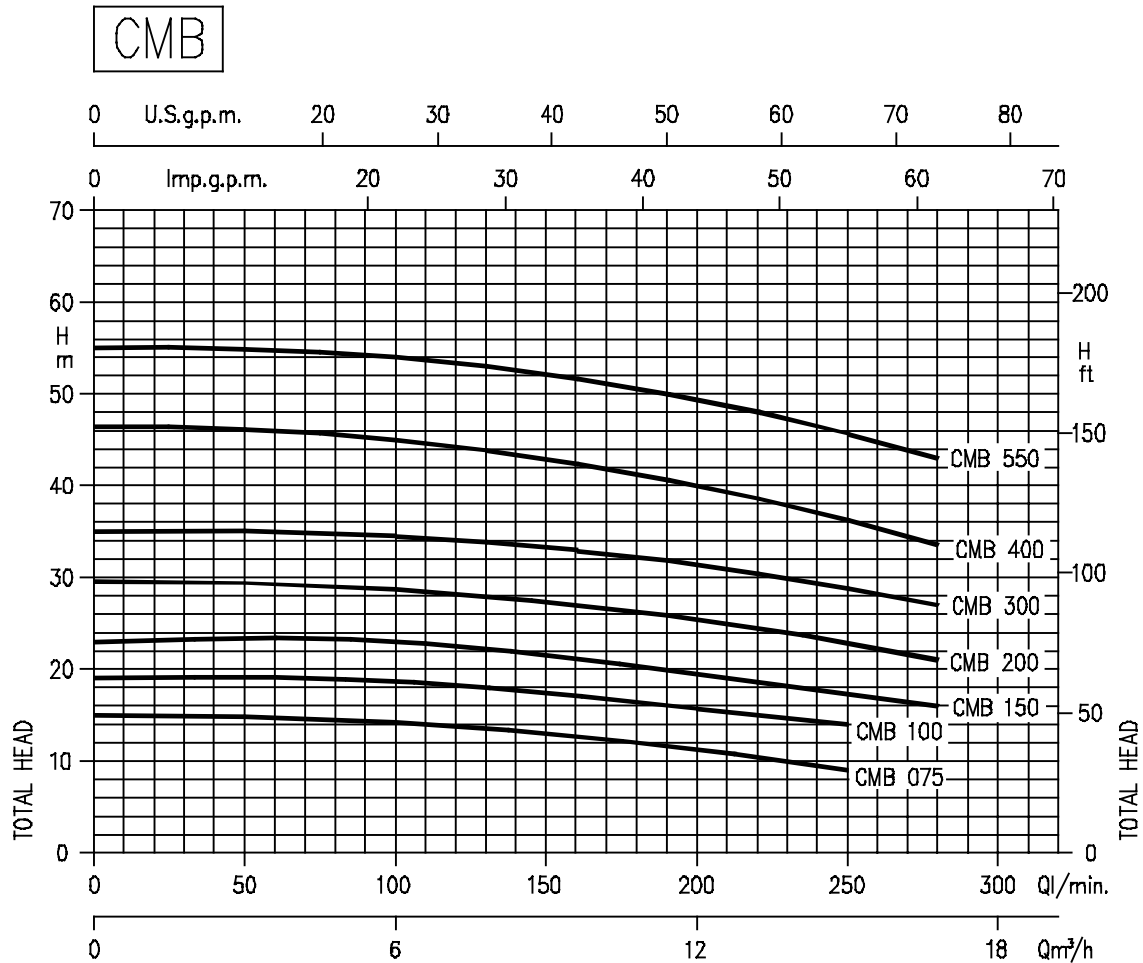

PERFORMANCE TABLE

Pump type		kW	Capacitor		Absorbed Current (A)			l/min m³/h	Q=Capacity					
Single-phase 230V 50Hz	Three-phase 230/400V 50Hz		µF	V _c	Single-phase	Three-phase 230V 400V			100 6	140 8,4	180 11	220 13	250 15	280 17
		H=Total head												
CMB 0.75 M	CMB 0.75 T	0,55	14	450	4,5	3,0	1,7	14,2	13,3	12	10,4	9	-	-
CMB 1.00 M	CMB 1.00 T	0,75	20	450	6,0	4,5	2,6	18,4	17,4	16,1	15,2	14	-	-
CMB 1.50 M	CMB 1.50 T	1,1	31,5	450	8,5	5,5	3,2	22,4	21,1	19,8	18	17,1	16	-
CMB 2.00 M	CMB 2.00 T	1,5	40	450	10,8	7,5	4,3	28,7	27,7	26,3	24,5	22,8	21	-
-	CMB 3.00 T	2,2	-	-	-	8,3	4,8	34,5	33,7	32,1	30,3	28,8	27	-
-	CMB 4.00 T	3,0	-	-	-	12,0	6,9	45	43,4	41,5	38,4	36,2	33,5	-
-	CMB 5.50 T	4,0	-	-	-	15,9	9,2	54	52,3	50,4	48,1	45,7	43	-

PERFORMANCE CURVES (according to ISO 9906 Annex A)

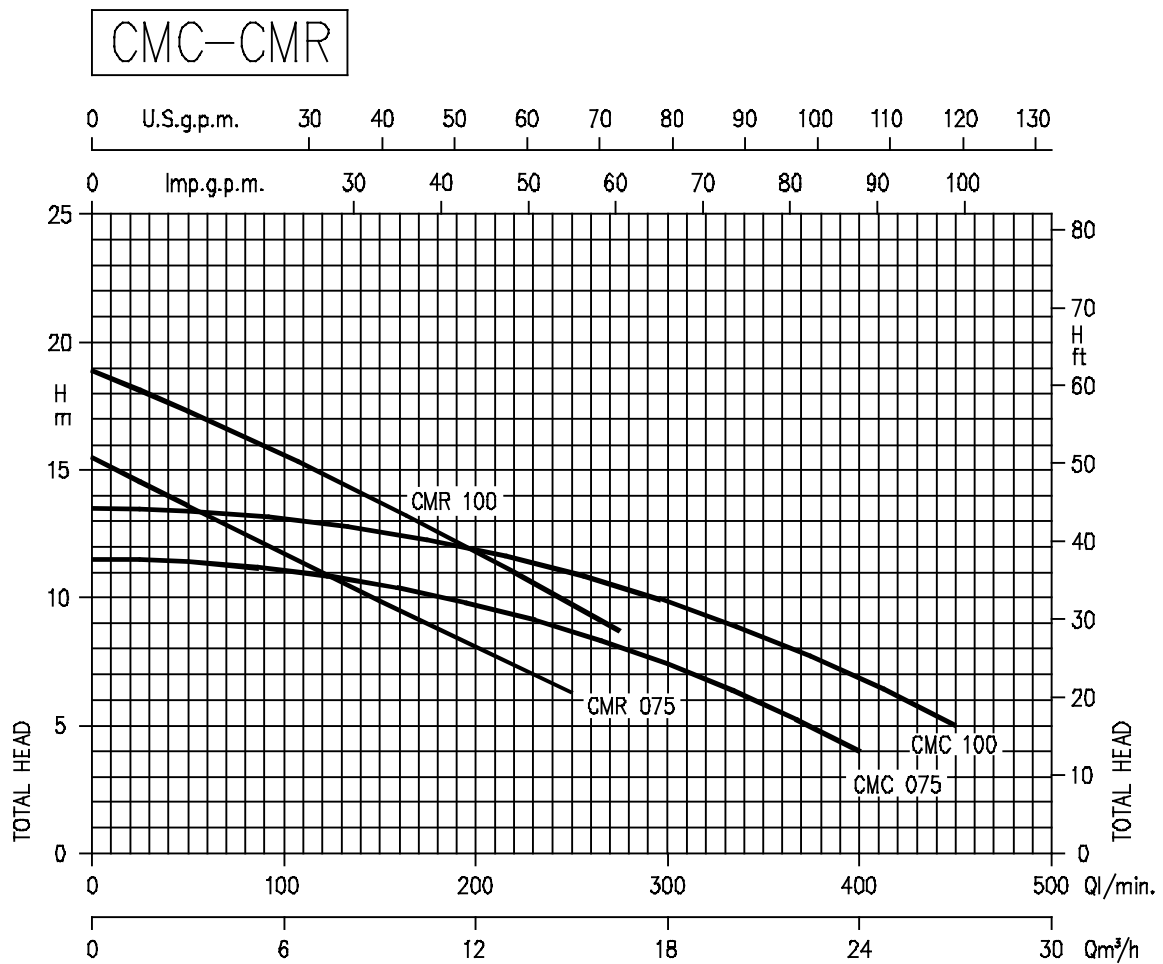

PERFORMANCE TABLE

Pump type		kW	Capacitor		Corrente as. (A)			l/min m³/h	Q=Capacity								
Single-phase 230V 50Hz	Three-phase 230/400V 50Hz		µF	V _c	Single-phase	Three-phase 230V	400V		50	100	150	200	250	275	350	400	450
								H=Total head									
CMC 0.75 M	CMC 0.75 T	0,55	14	450	4,2	2,8	1,6	11,4		10,6		8,8		5,9	4	-	
CMC 1.00 M	CMC 1.00 T	0,75	20	450	5,3	3,5	2,0	13,4		12,6		11		8,6	6,8	5	
CMR 0.75 M	CMR 0.75 T	0,55	14	450	3,8	2,8	1,6	13,6	11,4		8,1	6,3	-				
CMR 1.00 M	CMR 1.00 T	0,75	20	450	4,85	3,5	2,0	17,3	15,4		11,5	9,6	8,7				

PERFORMANCE CURVES (according to ISO 9906 Annex A)

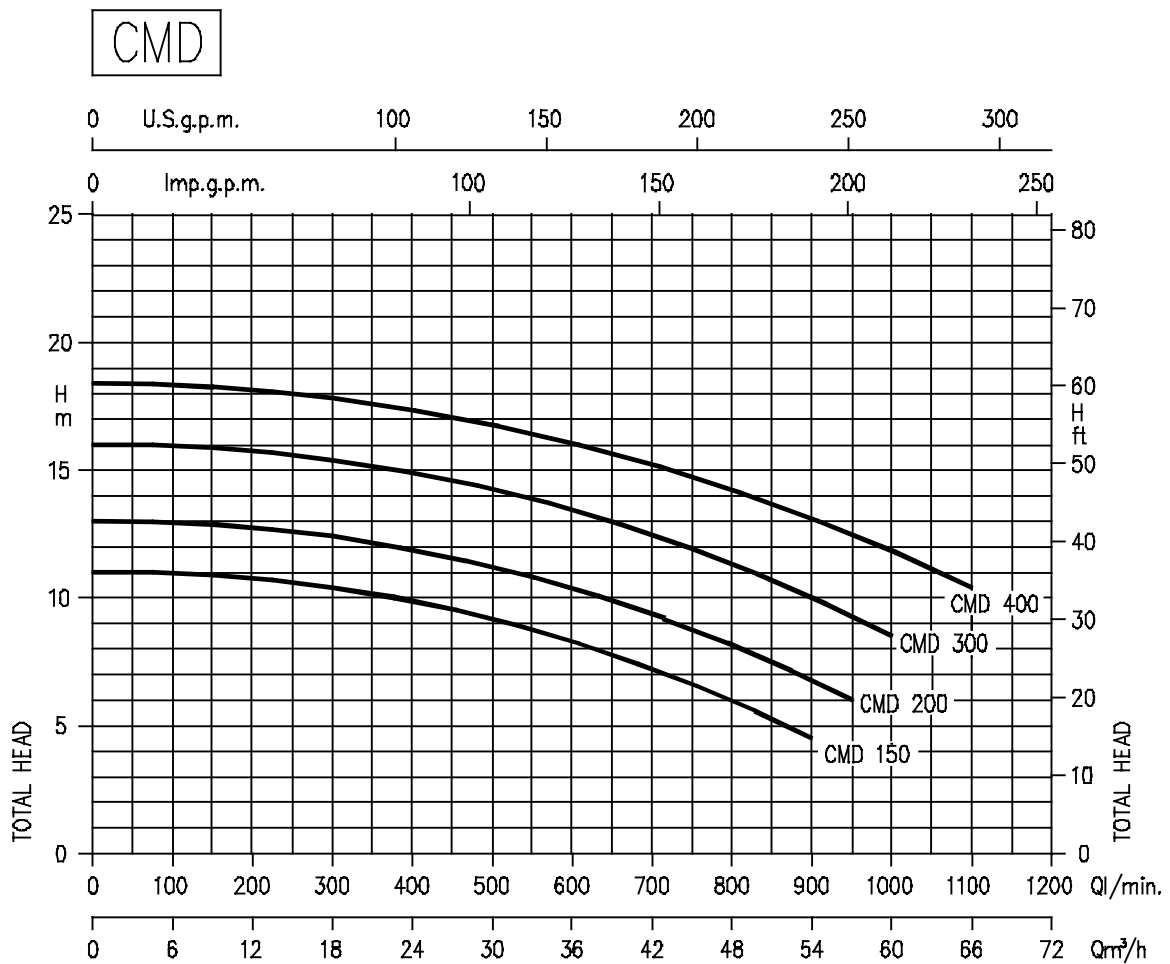

PERFORMANCE TABLE

Pump type		kW	Capacitor		Absorbed Current (A)			l/min m³/h	Q=Capacity							
Single-phase 230V 50Hz	Three-phase 230/400V 50Hz		μF	V _c	Single-phase	Three-phase 230V	400V		300	400	600	800	900	950	1000	1100
								H=Total head								
CMD 1.50 M	CMD 1.50 T	1,1	31,5	450	8,9	5,9	3,4	10,4	9,9	8,4	6	4,5	-	-	-	
CMD 2.00 M	CMD 2.00 T	1,5	40	450	10,8	7,5	4,3	12,4	11,9	10,5	8,3	6,8	6	-	-	
-	CMD 3.00 T	2,2	-	-	-	9,0	5,2	15,4	14,9	13,5	11,4	10	9,3	8,5	-	
-	CMD 4.00 T	3,0	-	-	-	12,3	7,1	17,8	17,3	16,1	14,2	13,1	12,5	11,8	10,4	