

In-line centrifugal pumps made of stainless steel AISI 304. Applications include chilled water, air-conditioning systems and heating systems for secondary hot water and general low-pressure applications in industry. Its light construction means installation can be achieved with 1 person where conventionally heavy cast iron & bronze pumps require additional personnel and lifting equipment.



SPECIFICATIONS

- Maximum positive suction pressure: 2 bar for all single-phase and for LPS 25 three-phase, 4 bar for LPS 32-40-50 three-phase
- Maximum liquid temperature: 100°C

MATERIALS

- Pump casing, impeller and casing cover in AISI 304
- Shaft in AISI 303
- Bracket and motor casing in aluminium
- Mechanical seal in carbon/ceramic/NBR

TECNICAL DATA

- Asynchronous 2 poles motor
- Insulation class F
- Protection degree IP55
- 1~230V ± 10% 50Hz - 3~400V ± 10% 50Hz
- Permanent split capacitor and automatic thermal overload protection for single-phase version
- Thermal protection to be provided by the user for three-phase version
- Flange: PN10

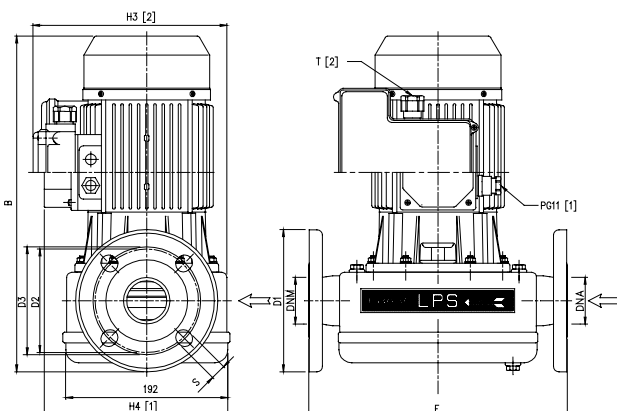

DIMENSIONAL TABLE

Pump type	Dimension (mm)											Weight kg
	E	B	H3	H4	T	DNA	DNM	D1	D2	D3	S	
LPS 25/08	300	320,5	181	171	PG11	25	25	115	85	85	14	12,8
LPS 25/15	300	320,5	181	171	PG11	25	25	115	85	85	14	12,8
LPS 25/25	300	320,5	181	171	PG11	25	25	115	85	85	14	12,9
LPS 32/25	305	340	181	171	PG11	32	32	140	100	100	18	14,6
LPS 32/40	305	340	181	171	PG11	32	32	140	100	100	18	14,6
LPS 40/25	305	345	181	171	PG11	40	40	150	105	110	18	13,0
LPS 40/40	305	345	181	171	PG11	40	40	150	105	110	18	14,0
LPS 40/75	305	345	181	171	PG11	40	40	150	105	110	18	13,0
LPS 50/40	310	357,5	181	171	PG11	50	50	165	120	125	18	14,5
LPS 50/75	310	357,5	181	171	PG11	50	50	165	120	125	18	15,0
LPS 50/150	310	389,5	213	194	PG13,5	50	50	165	120	125	18	18,5

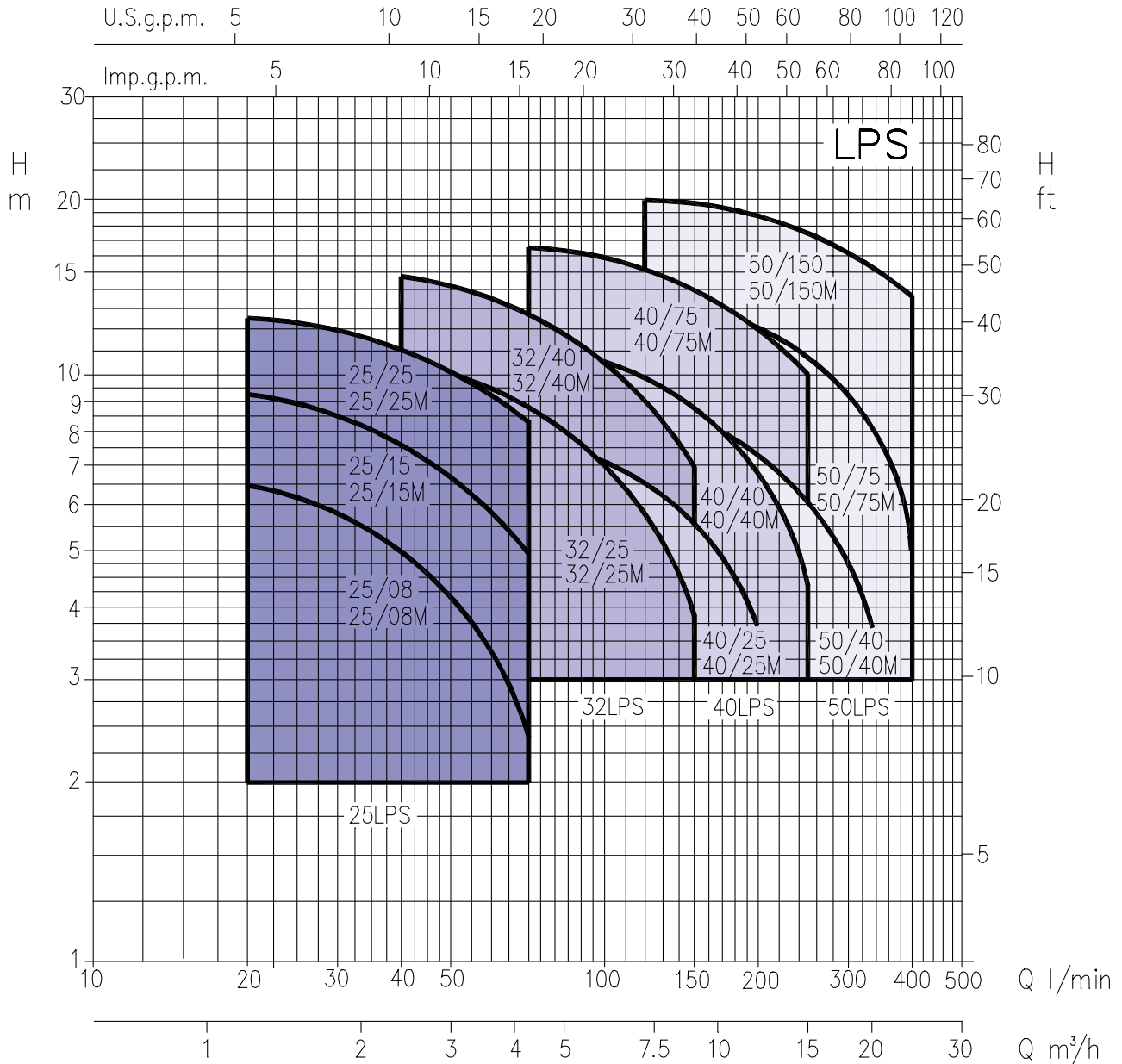
PERFORMANCE CHART (according to ISO 9906 Annex A)

PERFORMANCE TABLE

Pump type	kW	Capacitor		Absorbed Current (A)			l/min m³/h	Q=Capacity											
		Single-phase 230V 50Hz	Three-phase 230/400V 50Hz	μF	V _c	1~		3~ 230V	400V	20	40	70	100	120	150	200	250	320	400
LPS 25/08 M	0,08			12,5	450	1,51	1,7	1,01	6,5	5	2,4	-	-	-	-	-	-	-	-
LPS 25/15 M	0,15			12,5	450	1,67	1,8	1,03	9,3	7,8	4,9	-	-	-	-	-	-	-	-
LPS 25/25 M	0,25			12,5	450	2,04	1,9	1,11	12,5	11,1	8,4	-	-	-	-	-	-	-	-
LPS 32/25 M	0,25			12,5	450	2,0	1,8	1,03	-	10,7	9,1	7,2	5,9	3,9	-	-	-	-	-
LPS 32/40 M	0,4			12,5	450	2,74	2,2	1,25	-	14,5	12,7	10,6	9,2	7	-	-	-	-	-
LPS 40/25 M	0,25			12,5	450	1,98	1,9	1,09	-	-	7,8	7,1	6,6	5,6	3,7	-	-	-	-
LPS 40/40 M	0,4			12,5	450	2,75	2,2	1,25	-	-	11,3	10,4	9,9	8,7	6,9	4,4	-	-	-
LPS 40/75 M	0,75			25	450	4,86	4,0	2,29	-	-	16,6	16	15,2	14,1	12,3	10,1	-	-	-
LPS 50/40 M	0,4			12,5	450	2,74	2,2	1,25	-	-	-	-	9,1	8,8	7,4	5,9	3,5	-	-
LPS 50/75 M	0,75			25	450	4,9	3,9	2,26	-	-	-	-	13,8	13,3	12,3	10,7	8,2	5	-
LPS 50/150 M	1,5			35	450	8,07	5,7	3,31	-	-	-	-	19,8	19,3	18,7	17,8	16	13,7	-

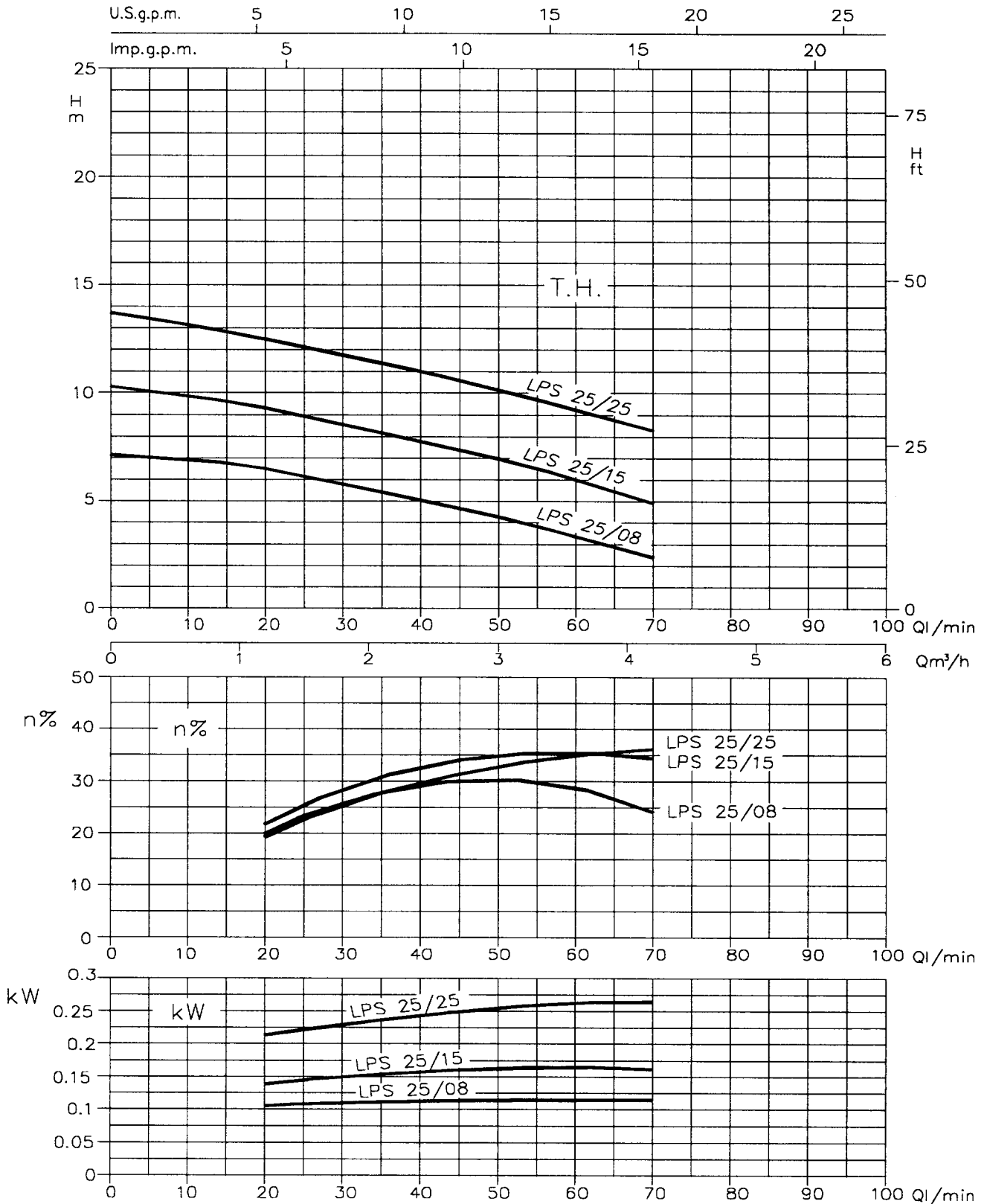
PERFORMANCE CURVES LPS 25 series (according to ISO 9906 Annex A)

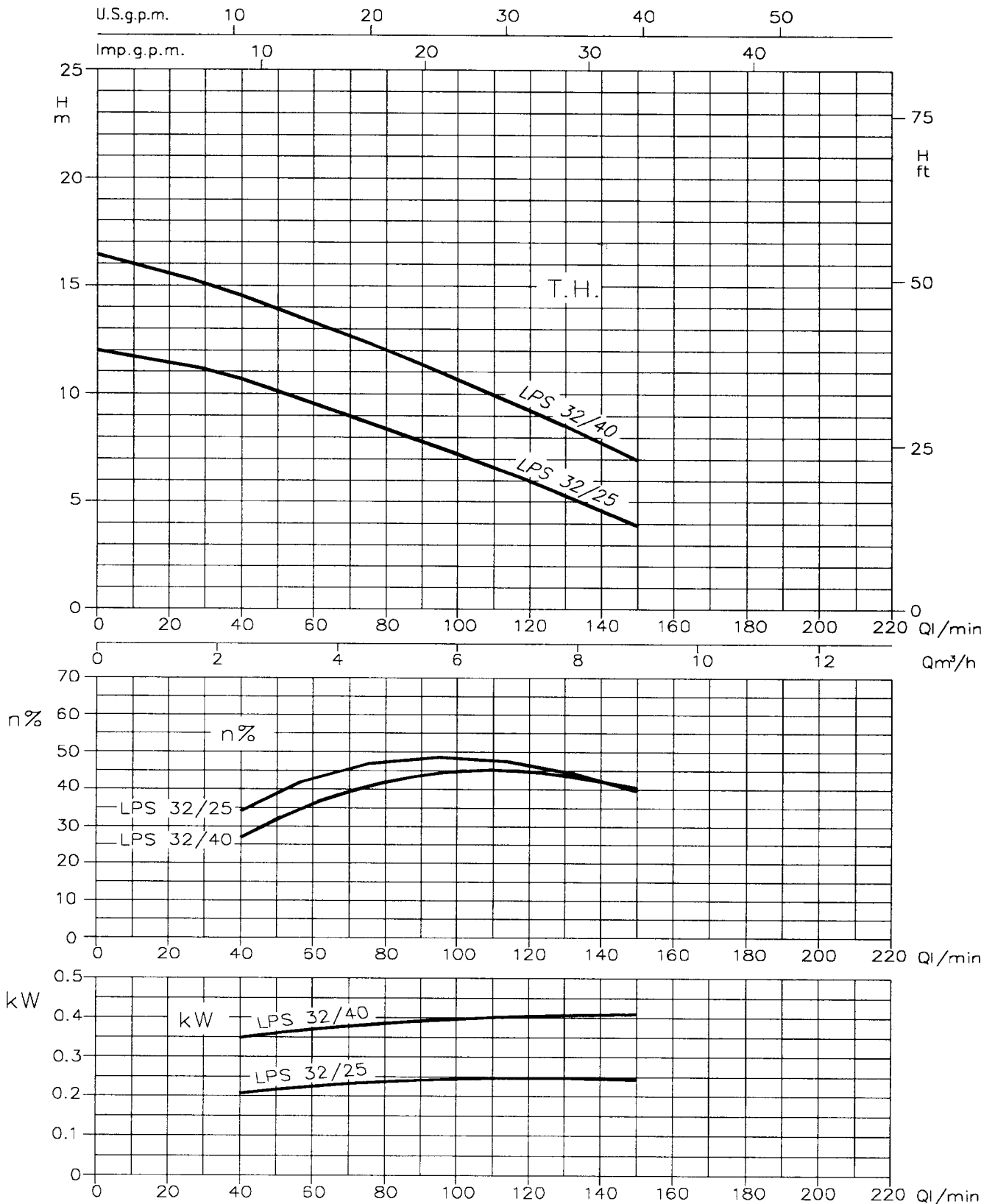

PERFORMANCE CURVES LPS 32 series (according to ISO 9906 Annex A)



PERFORMANCE CURVES LPS 40 series (according to ISO 9906 Annex A)

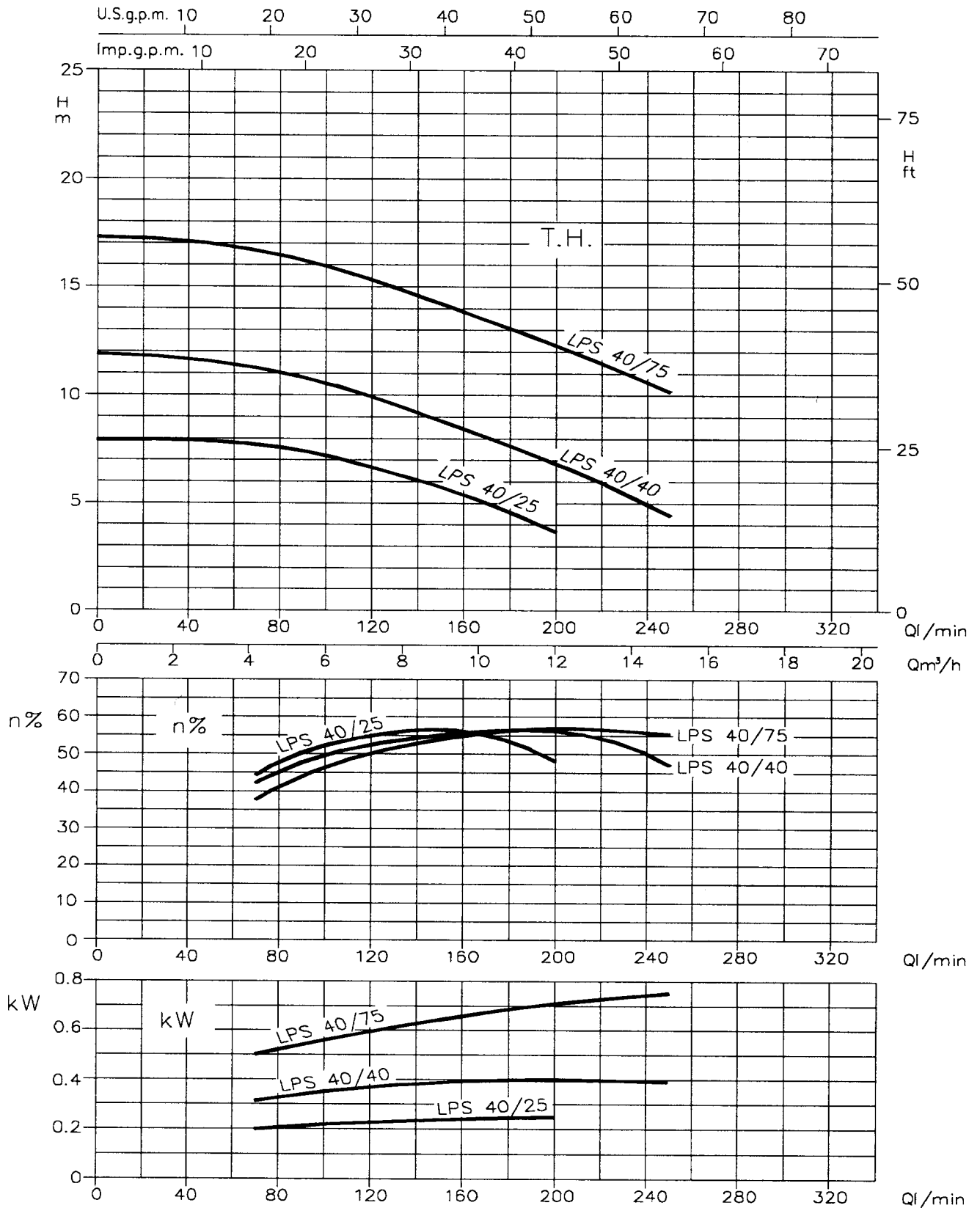

PERFORMANCE CURVES LPS 50 series (according to ISO 9906 Annex A)

