

E Series

End Suction

Centrifugal Pump DIN 24255



MATERIALS OF CONSTRUCTION

Part	Material
Casing	Cast Iron
Impeller	Bronze
Wear Ring	Cast Iron/Bronze*
Shaft	Stainless Steel
Shaft Nut	Bronze
Shaft Sleeve	Stainless Steel
Lantern Ring	Cast Iron/Bronze*
Gland	Cast Iron

* Bronze available on request.

All AISI 304 and 316 wetted parts are available on request.

MATERIALS SPECIFICATION

Material	Nearest Equivalent Standard			
	DIN	American	British	Australian
Cast Iron	DIN 1691 GG-25	ASTM A48 Class 30	BS 1452 Gr 260	AS 1830 T 260
Bronze	DIN 1714 G-CuAl 10Fe3	ASTM B148 C952	BS 1400 AB1	AS 1565 C952
Stainless Steel	DIN 17440 X20CR13	AISI 420	BS 970 Gr 420S37	AS 1444 Gr 420

ELECTRA BACK PULL-OUT FEATURE

This design feature allows the complete rotating element to be removed for servicing without disconnecting pipework. If a spacer coupling is fitted then motor does not have to be moved. On re-assembly of pump coupling re-alignment problems are completely eliminated.

MARKET SECTORS

Building Services, RHVAC, Agriculture, Civil, Industries

APPLICATION

Electra E series is suitable for handling Clear water and similar liquid. Mainly used in the following application.

- Water Supply
- Pressure Boosting
- Air Condition
- Refrigeration
- Heating and Ventilating
- Irrigation
- Fire Protection
- Industrial used

SPECIFICATIONS

Capacity : up to 540 m³/hr, 2 poles
up to 1900 m³/hr, 4 poles

Head : up to 150 m, 2 poles
up to 90 m, 4 poles

Pump Size : DN 32-DN 300

Speed : up to 3500 rpm

Operating Temperature : - 10°C to 105°C
For higher rating temperature application, please contact local distributor.

Operating Pressure : up to 1600 kPa
(Maximum pressure will vary depending on particular pump model, **higher ratings available on application.**)

Mechanical Seal made of carbon/ceramic/NBR
according to DIN 24960 Standard. Alternative materials are available on application.

Oil Lubrication complete with level sight glass is available on stock.

Counter-Clockwise Rotation when looking at pump from the suction side.

IDENTIFICATION CODE

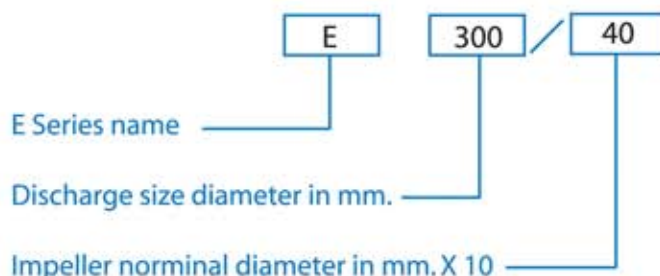

PUMP CONSTRUCTION

Electra E series fully comply to both dimension standards & performance for the International Standards DIN 24255

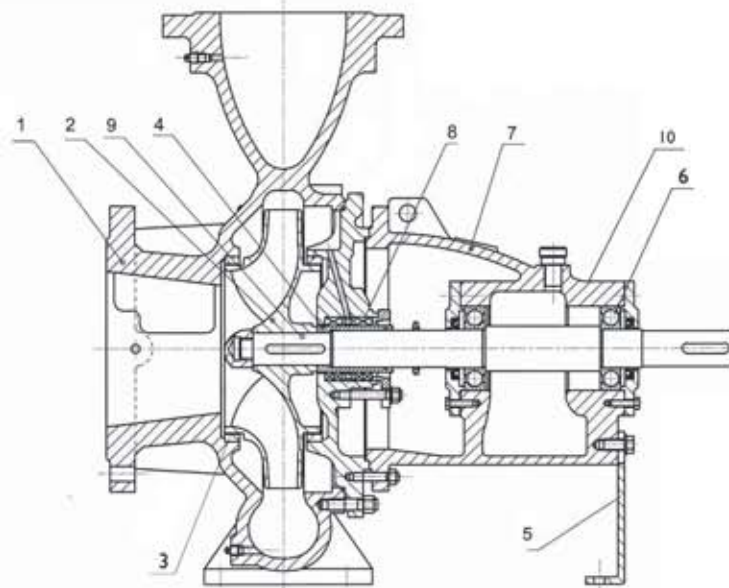

1) VOLUTE CASING

High efficiency volute with self-venting centre line discharge. **Cast iron volute with integrally cast feet.**

2) IMPELLER

Double shrouded hydraulic and mechanical balanced **impellers in Bronze standard.** Stainless steel or cast iron available on request.

3) WEAR RING

Replaceable **cast iron wear rings** fitted to all volutes and also back covers of larger pumps. Bronze available on request.

4) SHAFT SLEEVE

Replaceable **stainless steel shaft sleeve** which enables any scoring under gland packing be rectified by repairing the sleeve and not the whole shaft.

5) SUPPORT FOOT

A removable support foot is fitted at the drive end for greater rigidity.

6) BEARINGS

Bearing are pre-packed and sealed for life. Open bearings for **grease nipples or oil lubrication** complete with oil fill plus drain, oil seals and level sight glass.

7) BEARING HOUSING

Cast iron bearing housing secured to casing cover and volute. Only three bearing housings are required for the whole pump range which ensures interchangeability or parts and minimize stock inventory.

8) STUFFING BOX

Standard pump is gland packed with a stuffing box incorporating a lantern ring. Mechanical seal type can be supplied as option.

9) SHAFT

Only six **stainless steel shaft** assemblies are required to cover the entire range, thus giving common interchangeable parts such as bearing, shaft sleeves, seals and impeller fastenings.

10) PAINTING

Pump is thoroughly cleaned of scale and other foreign material. The pump is painted with high quality enamel paint.

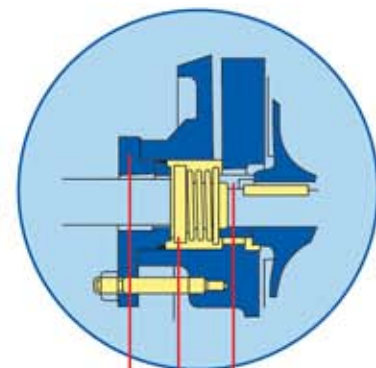

SHAFT SLEEVE
MECHANICAL SEAL
SEAL PLATE

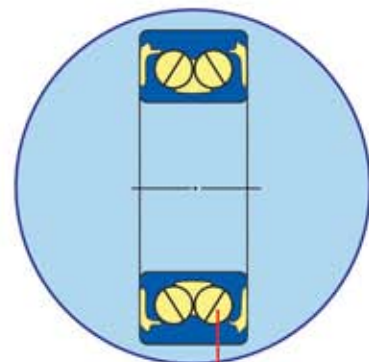

DOUBLE ROLLS BALL BEARING
FOR H MODELS

PERFORMANCE CHART

$n = 1450 \text{ r/min}$

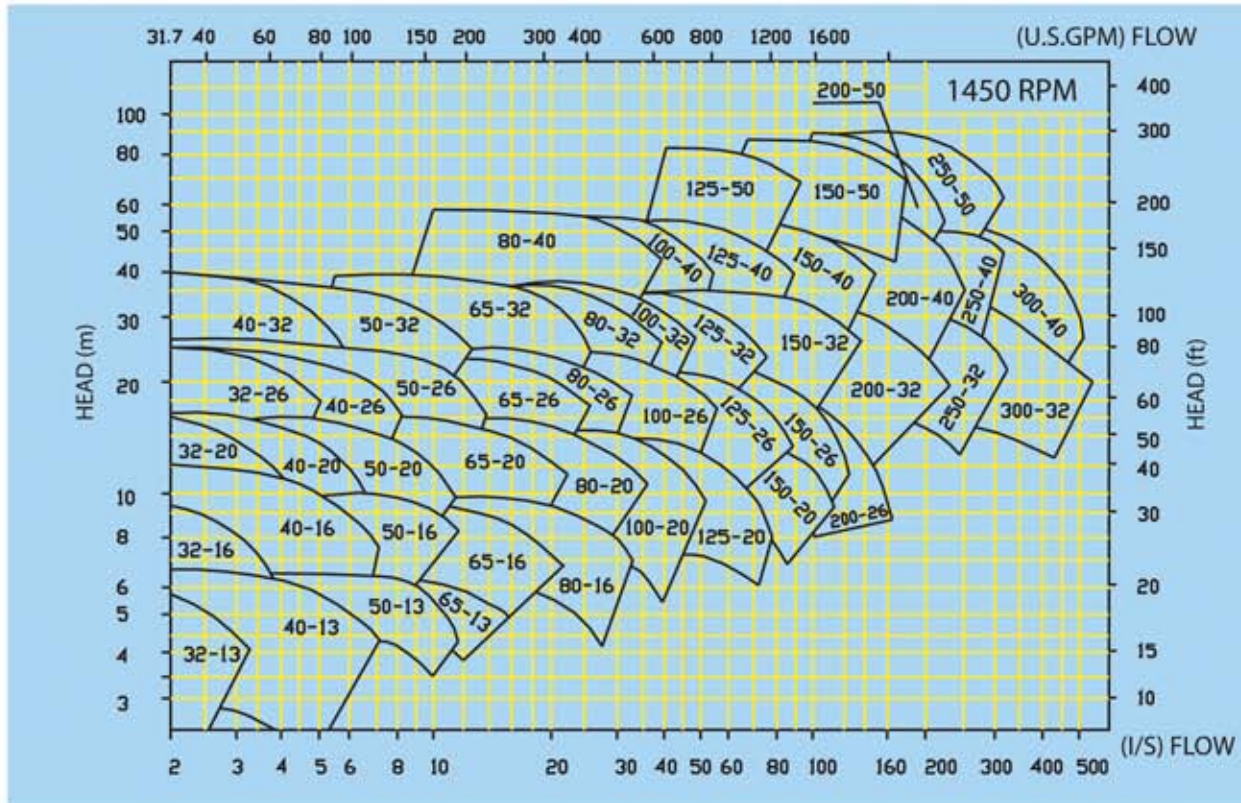

$n = 2900 \text{ r/min}$

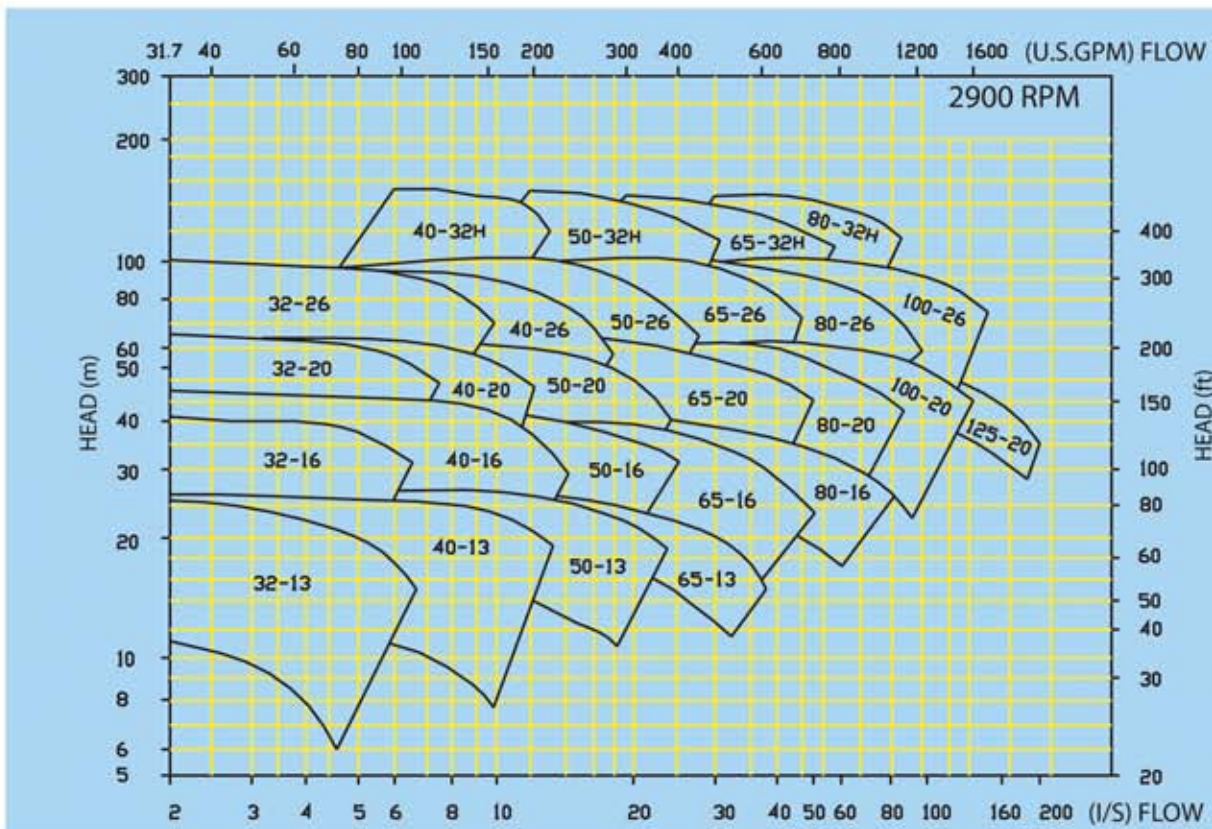

INSTALLATION DIMENSION (MM)

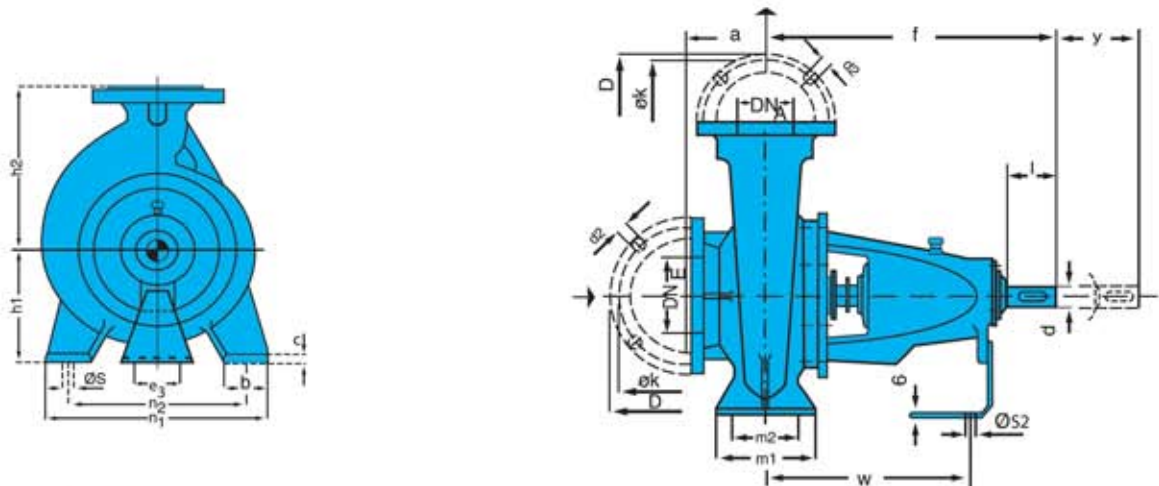

DIMENSION :

PUMP SIZE	DN _E	DN _A	PUMP DIMENSION				PUMP FOOT DIMENSION											SHAFT END	
			a	f	h1	h2	b	c	m1	m2	n1	n2	n3	ø s1	ø s2	w	d	l	
E32/13	ø 50	ø 32	80	360	112	140	50	14	100	70	190	140	100	14	14	267	ø 24	50	
E32/16	ø 50	ø 32	80	360	132	160	50	14	100	70	240	190	100	14	14	267	ø 24	50	
E32/20	ø 50	ø 32	80	360	160	180	50	14	100	70	240	190	100	14	14	267	ø 24	50	
E32/26	ø 50	ø 32	100	360	180	225	65	14	125	95	320	250	110	14	14	267	ø 24	50	
E40/13	ø 65	ø 40	80	360	112	140	50	14	100	70	210	160	100	14	14	267	ø 24	50	
E40/16	ø 65	ø 40	80	360	132	160	50	14	100	70	240	190	100	14	14	267	ø 24	50	
E40/20	ø 65	ø 40	100	360	160	180	50	14	100	70	265	212	110	14	14	267	ø 24	50	
E40/26	ø 65	ø 40	100	360	180	225	65	14	125	95	320	250	110	14	14	267	ø 24	50	
E40/32H*	ø 65	ø 40	125	470	200	225	65	14	125	95	345	280	110	14	14	342	ø 32	80	
E50/13	ø 65	ø 50	100	360	132	160	50	14	100	70	240	190	100	14	14	267	ø 24	50	
E50/16	ø 65	ø 50	100	360	160	180	50	14	100	70	265	212	110	14	14	267	ø 24	50	
E50/20	ø 65	ø 50	100	360	160	200	50	14	100	70	265	212	110	14	14	267	ø 24	50	
E50/26	ø 65	ø 50	100	360	180	225	65	14	125	95	320	250	110	14	14	267	ø 24	50	
E50/32H*	ø 65	ø 50	125	470	225	280	65	16	125	95	345	280	110	14	14	267	ø 32	80	
E65/13	ø 80	ø 65	100	360	160	180	65	14	125	95	280	212	110	14	14	267	ø 24	50	
E65/16	ø 80	ø 65	100	360	160	200	65	14	125	95	280	212	110	14	14	267	ø 24	50	
E65/20	ø 80	ø 65	100	360	180	225	65	14	125	95	320	250	110	14	14	267	ø 24	50	
E65/26	ø 80	ø 65	100	470	200	250	80	16	160	120	360	280	110	17.5	14	342	ø 32	80	
E65/32H*	ø 80	ø 65	125	470	225	280	80	16	160	120	400	315	110	17.5	14	342	ø 32	80	
E80/16	ø 100	ø 80	125	360	180	225	65	14	125	95	320	250	110	14	14	267	ø 24	50	
E80/20	ø 100	ø 80	125	470	180	250	65	14	125	95	345	280	110	14	14	342	ø 32	80	
E80/26	ø 100	ø 80	125	470	200	280	80	16	160	120	400	315	110	17.5	14	342	ø 32	80	
E80/32H*	ø 100	ø 80	125	470	250	315	80	16	160	120	400	315	110	17.5	14	342	ø 32	80	
E80/40*	ø 100	ø 80	125	520	280	355	85	16	160	120	400	355	110	17.5	14	370	ø 42	110	
E100/20	ø 125	ø 100	125	470	200	280	80	16	160	120	360	280	110	17.5	14	342	ø 32	80	
E100/26	ø 125	ø 100	140	470	225	280	80	16	160	120	400	315	110	17.5	14	342	ø 32	80	
E100/32	ø 125	ø 100	140	470	250	315	80	16	160	120	400	315	110	17.5	14	342	ø 32	80	
E100/40	ø 125	ø 100	140	530	280	355	100	18	200	150	500	400	110	23	14	370	ø 42	110	

INSTALLATION DIMENSION (MM)

PUMP SIZE	DN _E	DN _A	PUMP DIMENSION				PUMP FOOT DIMENSION										SHAFT END	
			a	f	h1	h2	b	c	m1	m2	n1	n2	n3	ø s1	ø s2	w	d	l
E125/20*	ø 150	ø 125	140	470	250	315	80	16	160	120	400	315	110	17.5	14	342	ø 32	80
E125/26	ø 150	ø 125	140	470	250	355	80	16	160	120	400	315	110	17.5	14	342	ø 32	80
E125/32	ø 150	ø 125	140	530	280	355	100	18	200	150	500	400	110	23	14	370	ø 42	110
E125/40	ø 150	ø 125	140	530	315	400	100	18	200	150	500	400	110	23	14	370	ø 42	110
E125/50*	ø 150	ø 125	160	670	375	500	120	25	200	150	500	450	140	23	14	511	ø 55	110
E150/20*	ø 200	ø 150	160	495	280	400	100	20	200	150	550	450	110	23	14	342	ø 32	80
E150/26*	ø 200	ø 150	160	530	250	355	100	18	200	150	450	350	110	23	14	370	ø 42	110
E150/32	ø 200	ø 150	160	530	280	400	100	18	200	150	550	450	110	23	14	370	ø 42	110
E150/40	ø 200	ø 150	160	530	315	450	100	18	200	150	550	450	110	23	14	370	ø 42	110
E150/50*	ø 200	ø 150	180	670	375	500	120	25	200	180	550	450	140	23	14	511	ø 55	110
E200/26*	ø 250	ø 200	180	550	280	400	100	25	200	150	550	450	110	27	14	389	ø 42	110
E200/32*	ø 250	ø 200	200	670	355	450	100	20	200	150	550	450	110	23	14	511	ø 48	110
E200/40*	ø 250	ø 200	200	670	355	500	120	20	200	150	550	450	110	23	14	511	ø 48	110
E200/50*	ø 250	ø 200	210	675	400	500	160	30	300	240	720	600	140	27	14	511	ø 55	110
E250/32*	ø 300	ø 250	200	670	355	525	100	24	250	175	600	500	110	23	14	511	ø 48	110
E250/40*	ø 300	ø 250	250	670	400	500	120	25	300	250	710	600	110	24	14	511	ø 55	110
E250/50*	ø 300	ø 250	240	875	425	545	160	30	300	200	720	600	140	27	19	625	ø 70	140
E300/40*	ø 350	ø 300	280	875	500	600	150	40	300	200	800	660	140	27	19	625	ø 70	140

* Additional sizes not contained in DIN 24255
H Models are supplied with double rolls ball bearing

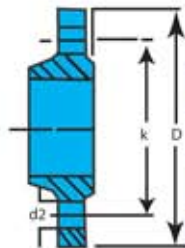

Flange mating dimension to ISO 2084 PN16 (DIN2533 PN16, BS4504 PN15)													
DN _A / DN _E	32	40	50	65	80	100	125	150	200	250	300	350	400
ø D	140	150	165	185	200	220	250	285	340	405	460	520	580
ø k	100	110	125	145	160	180	210	240	295	355	410	470	525
d2 x number	17.5x4	17.5x4	17.5x4	17.5x4	17.5x8	17.5x8	17.5x8	22x8	22x12	26x12	26x12	26x12	30x16

Distributor :

We reserve the rights to change subjects without notice.