

CEA-CA SERIES

STAINLESS STEEL THREADED CENTRIFUGAL PUMPS

Wide range of pumps for domestic and industrial applications.

Single-impeller (CEA) and dual-impeller (CA) models available.

- ❑ **IN THE STANDARD VERSION ALL COMPONENTS IN CONTACT WITH THE PUMPED LIQUID ARE MADE OF STAINLESS STEEL (AISI 304 OR AISI 316)**
- ❑ **IP 55 MOTOR PROTECTION**

APPLICATIONS

- **Handling of liquids compatible with AISI 304 stainless steel in a wide variety of civil and industrial systems.**
- Water circulation for domestic use.
- Sprinkler systems.
- Composition of surge tank units for pressure boosting in various applications.

SPECIFICATIONS

- **Single-impeller CEA series, dual-impeller CA series.**
- **Delivery:** up to **31 m³/h.**
- **Head:** up to **62 m.**
- **Maximum operating pressure: 8 bar.**
- **Continuous duty.**
- **Temperature of pumped liquid: -10°C to 85°C (special CEA-V CA-V version, with O-ring or FPM seals, is available for temperatures up to +110°C).**
- Enclosed motor with external ventilation and aluminium alloy finned casing.
- Versions:
 - **Single-phase** 220-240 V 50 Hz, permanently connected capacitor and built-in automatic reset overload protection up to 1,5 kW.
 - **Three-phase** 220-240/380-415 V 50 Hz, overload protection to be provided by user.
- Power up to 3 kW.
- Class **F Insulation.**
- **IP 55 protection.**



TABLE OF MATERIALS

PART	MATERIAL	
	CEA	CA
Pump body, Flange, Seal housing, Diffuser, Impeller	STAINLESS STEEL (AISI 304 - DIN 1.4301)	
Shaft extension	STAINLESS STEEL (AISI 316 - DIN 1.4401)	STAINLESS STEEL (AISI 304 - DIN 1.4301)
Fill and drain plugs	STAINLESS STEEL (AISI 316 - DIN 1.4401)	
Mechanical seal	CARBON/CERAMIC/NBR	
O-ring seals	NBR	

CEA SERIES HYDRAULIC PERFORMANCE TABLE AT 2850 rpm 50 Hz

PUMP TYPE	RATED POWER		Q = DELIVERY																		
			l/min	0	30	40	60	80	100	120	140	160	180	200	250	300	350	400	430	480	520
	kw	HP	m ³ /h	0	1.8	2.4	3.6	4.8	6	7.2	8.4	9.6	10.8	12	15	18	21	24	26	29	31
			H = TOTAL HEAD METERS COLUMN OF WATER																		
CEA(M) 70/3	0.37	0.5	22.0	20.1	19.1	16.6	12.8														
CEA(M) 70/5	0.55	0.75	31.1	28.8	27.7	24.7	20.2														
CEA(M) 80/5	0.75	1	32.0	30.0	29.3	27.4	24.7	21.0													
CEA(M) 120/3	0.55	0.75	22.4			18.9	17.5	15.9	14.0	11.8	9.2										
CEA(M) 120/5	0.9	1.2	31.8			28.2	26.5	24.6	22.4	20.0	17.3										
CEA(M) 210/2	0.75	1	17.7						16.5	16.1	15.6	15.0	14.4	12.6	10.4						
CEA(M) 210/3	1.1	1.5	20.8						19.7	19.3	19.0	18.5	18.0	16.5	14.4						
CEA(M) 210/4	1.5	2	25.5						24.8	24.5	24.0	23.6	23.0	21.3	19.0						
CEA(M) 210/5	*1.85	2.5	29.0						28.2	27.9	27.5	27.1	26.6	25.1	23.1						
CEA(M) 370/1	1.1	1.5	16.3									15.5	15.2	14.3	13.0	11.4	9.4	8.1			
CEA(M) 370/2	1.5	2	20.4										19.1	18.3	17.2	15.8	14.1	13.0	10.8		
CEA(M) 370/3	*1.85	2.5	24.4										22.9	22.1	21.1	19.8	18.2	17.1	15.0	13.0	

* Singlephase version = 2.2 kW (3HP)

cea-2p50_a_th

PUMP TYPE SINGLE-PHASE	INPUT POWER*	INPUT CURRENT*	CAPACITOR
	kw	A	μF / 450 V
CEAM 70/3	0.6	2.72	14
CEAM 70/5	0.97	4.55	16
CEAM 80/5	1.07	4.87	20
CEAM 120/3	0.91	4.33	16
CEAM 120/5	1.39	6.24	25
CEAM 210/2	1.13	5.1	20
CEAM 210/3	1.48	6.68	30
CEAM 210/4	1.91	8.6	40
CEAM 210/5	2.31	10.6	50
CEAM 370/1	1.49	6.75	30
CEAM 370/2	2.05	9.26	40
CEAM 370/3	2.47	11.2	50

* Maximum value in specified range

PUMP TYPE THREE-PHASE	INPUT POWER*	INPUT CURRENT*	INPUT CURRENT*
	kw	A	A
CEA 70/3	0.61	2.51	1.45
CEA 70/5	0.88	2.86	1.65
CEA 80/5	1.06	3.65	2.11
CEA 120/3	0.82	2.74	1.58
CEA 120/5	1.32	4.52	2.61
CEA 210/2	1.12	3.76	2.17
CEA 210/3	1.43	4.68	2.7
CEA 210/4	1.84	6.04	3.49
CEA 210/5	2.28	8.35	4.82
CEA 370/1	1.44	4.71	2.72
CEA 370/2	1.99	6.32	3.65
CEA 370/3	2.47	8.63	4.98

cea-2p50_a_te

CEA-CA

CA SERIES HYDRAULIC PERFORMANCE TABLE AT 2850 rpm 50 Hz

PUMP TYPE	RATED POWER		Q = DELIVERY																		
			l/min	0	30	40	50	60	70	80	100	120	150	180	210						
	kw	HP	m ³ /h	0	1.8	2.4	3	3.6	4.2	4.8	6	7.2	9	10.8	12.6						
			H = TOTAL HEAD METERS COLUMN OF WATER																		
CA(M) 70/33	0.75	1	42.9	38.8	36.9	34.6	31.7	28.2	23.9												
CA(M) 70/34	0.9	1.2	48.8	45.1	43.2	40.7	37.7	34.0	29.5												
CA(M) 70/45	1.1	1.5	56.2	52.0	49.8	47.1	43.9	39.9	35.3												
CA(M) 120/33	1.1	1.5	44.3			39.1	37.8	36.4	34.8	31.4	27.6	21.0									
CA(M) 120/35	1.5	2	54.0			49.4	48.1	46.6	44.9	41.2	36.8	29.3									
CA(M) 120/55	*1.85	2.5	63.8			59.6	58.2	56.6	54.8	50.6	45.7	37.1									
CA(M) 200/33	*1.85	2.5	43.2			41.8	41.2	40.6	39.9	38.3	36.4	33.2	29.5	25.5							
CA 200/35	2.2	3	53.5			52.4	51.9	51.4	50.7	49.2	47.5	44.3	40.6	36.5							
CA 200/55	3	4	62.6			61.0	60.6	60.1	59.5	58.2	56.6	53.8	50.4	46.2							

* Singlephase version = 2.2 kW (3HP)

ca-2p50_a_th

PUMP TYPE SINGLE-PHASE	INPUT POWER*	INPUT CURRENT*	CAPACITOR
	kw	A	μF / 450 V
CAM 70/33	1.15	5.16	20
CAM 70/34	1.39	6.22	25
CAM 70/45	1.76	7.92	30
CAM 120/33	1.67	7.53	30
CAM 120/35	2.18	9.87	40
CAM 120/55	2.61	11.7	50
CAM 200/33	2.36	10.8	50
-	-	-	-
-	-	-	-

* Maximum value in specified range

PUMP TYPE THREE-PHASE	INPUT POWER*	INPUT CURRENT*	INPUT CURRENT*
	kw	A	A
CA 70/33	1.14	3.78	2.18
CA 70/34	1.32	4.52	2.61
CA 70/45	1.71	5.23	3.02
CA 120/33	1.62	5.06	2.92
CA 120/35	2.13	6.58	3.8
CA 120/55	2.62	8.89	5.13
CA 200/33	2.34	8.44	4.87
CA 200/35	3.14	9.18	5.3
CA 200/55	3.68	10.9	6.3

ca-2p50_a_te

**CEA70-CEA80 SERIES
OPERATING CHARACTERISTICS AT 2850 rpm 50 Hz**

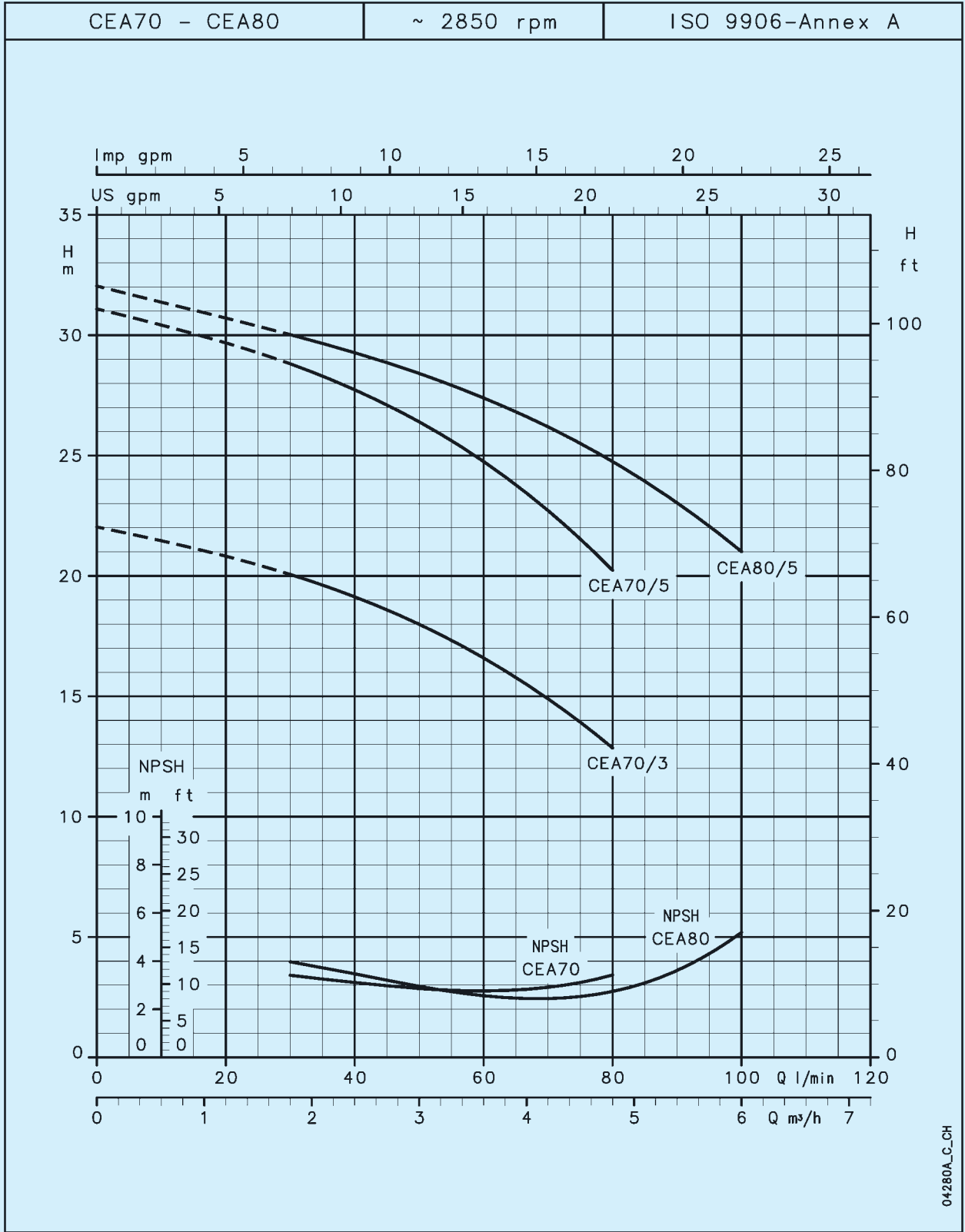

CEA-CA

These performances are valid for liquids with density $\rho = 1.0 \text{ kg/dm}^3$ and kinematic viscosity $\gamma = 1 \text{ mm}^2/\text{sec}$.

CEA120 SERIES
OPERATING CHARACTERISTICS AT 2850 rpm 50 Hz

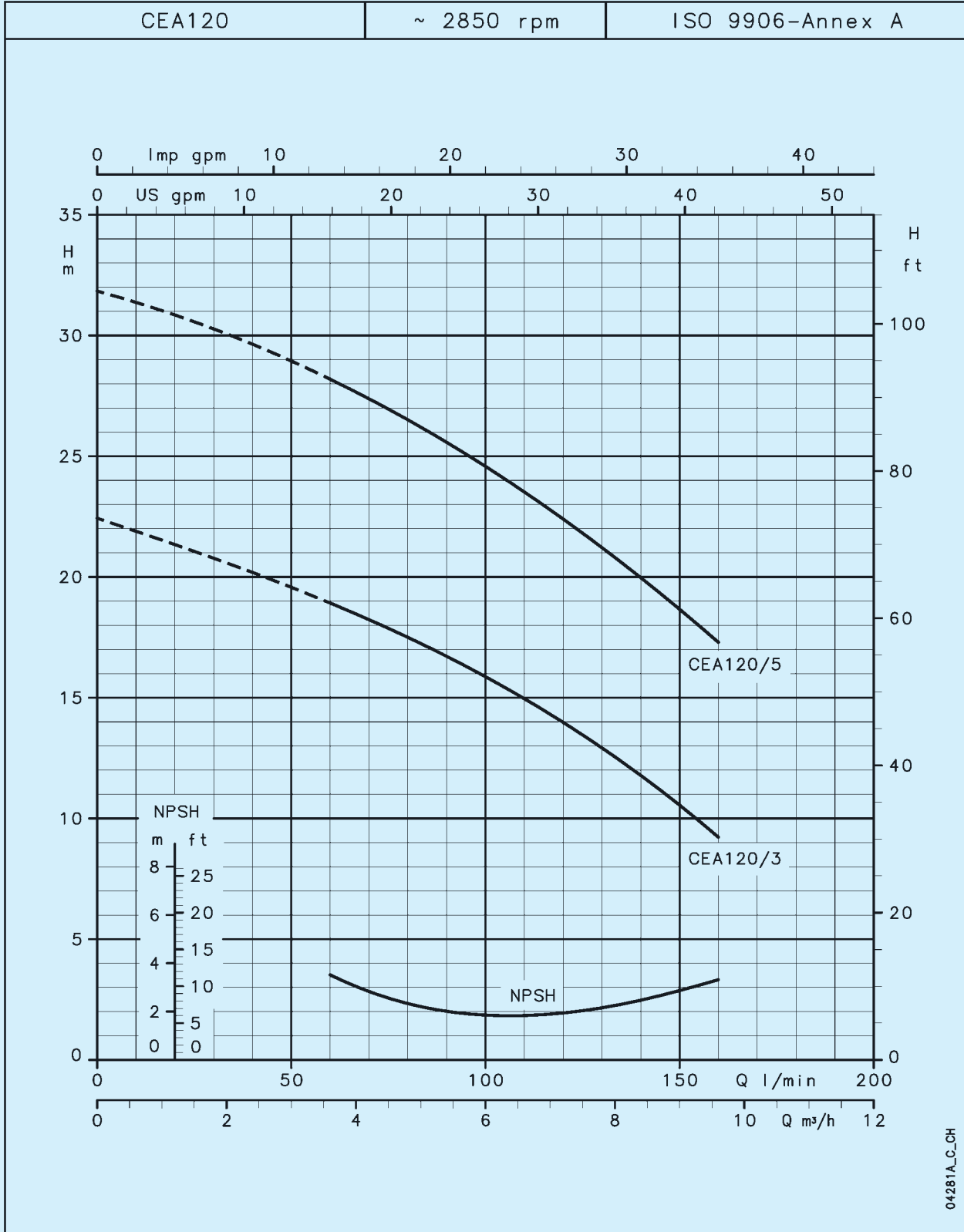

CEA-CA

These performances are valid for liquids with density $\rho = 1.0 \text{ kg/dm}^3$ and kinematic viscosity $\gamma = 1 \text{ mm}^2/\text{sec}$.

**CEA210 SERIES
OPERATING CHARACTERISTICS AT 2850 rpm 50 Hz**

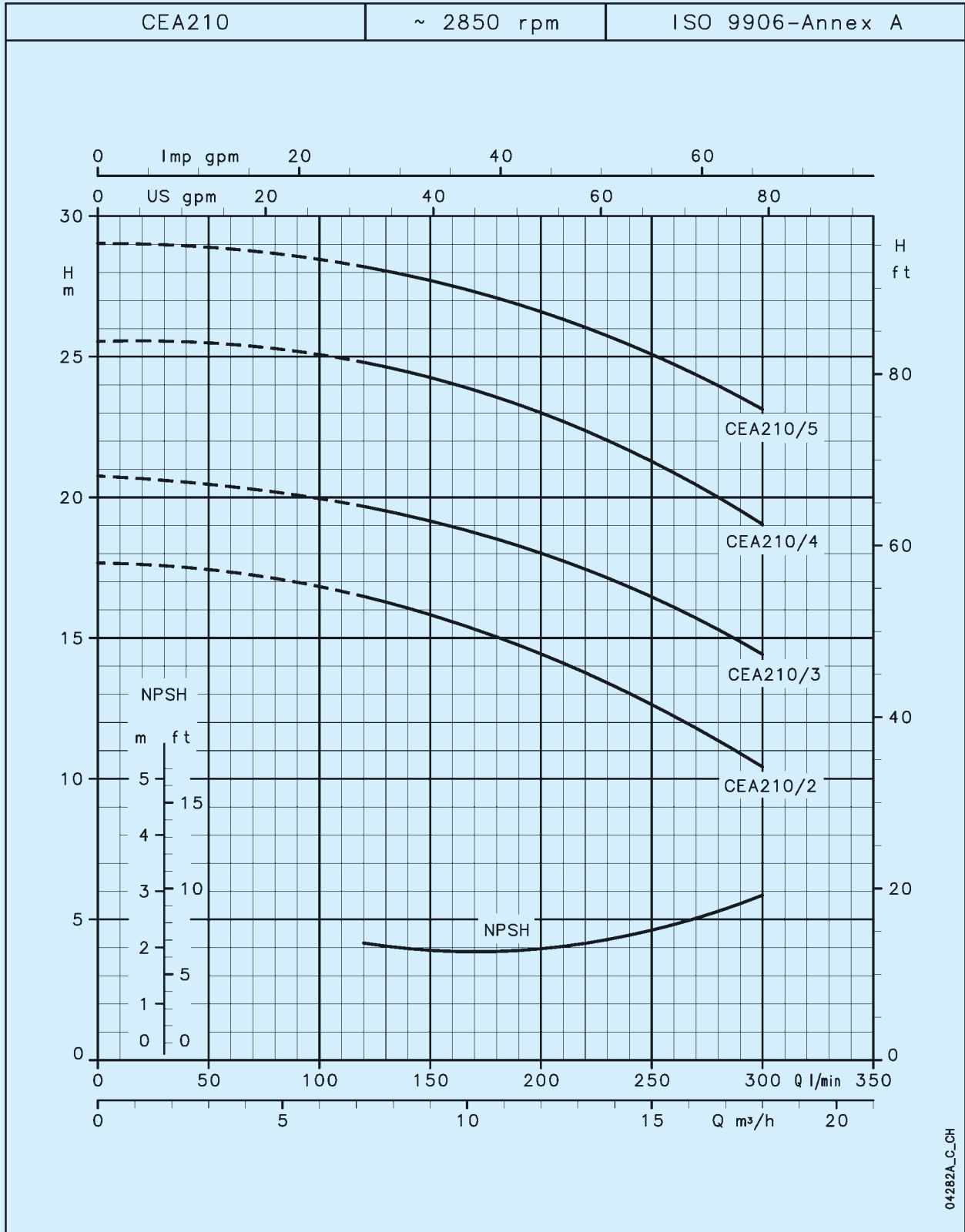

These performances are valid for liquids with density $\rho = 1.0 \text{ kg/dm}^3$ and kinematic viscosity $\gamma = 1 \text{ mm}^2/\text{sec}$.

CEA-CA

04282A_C_CH

CEA370 SERIES
OPERATING CHARACTERISTICS AT 2850 rpm 50 Hz

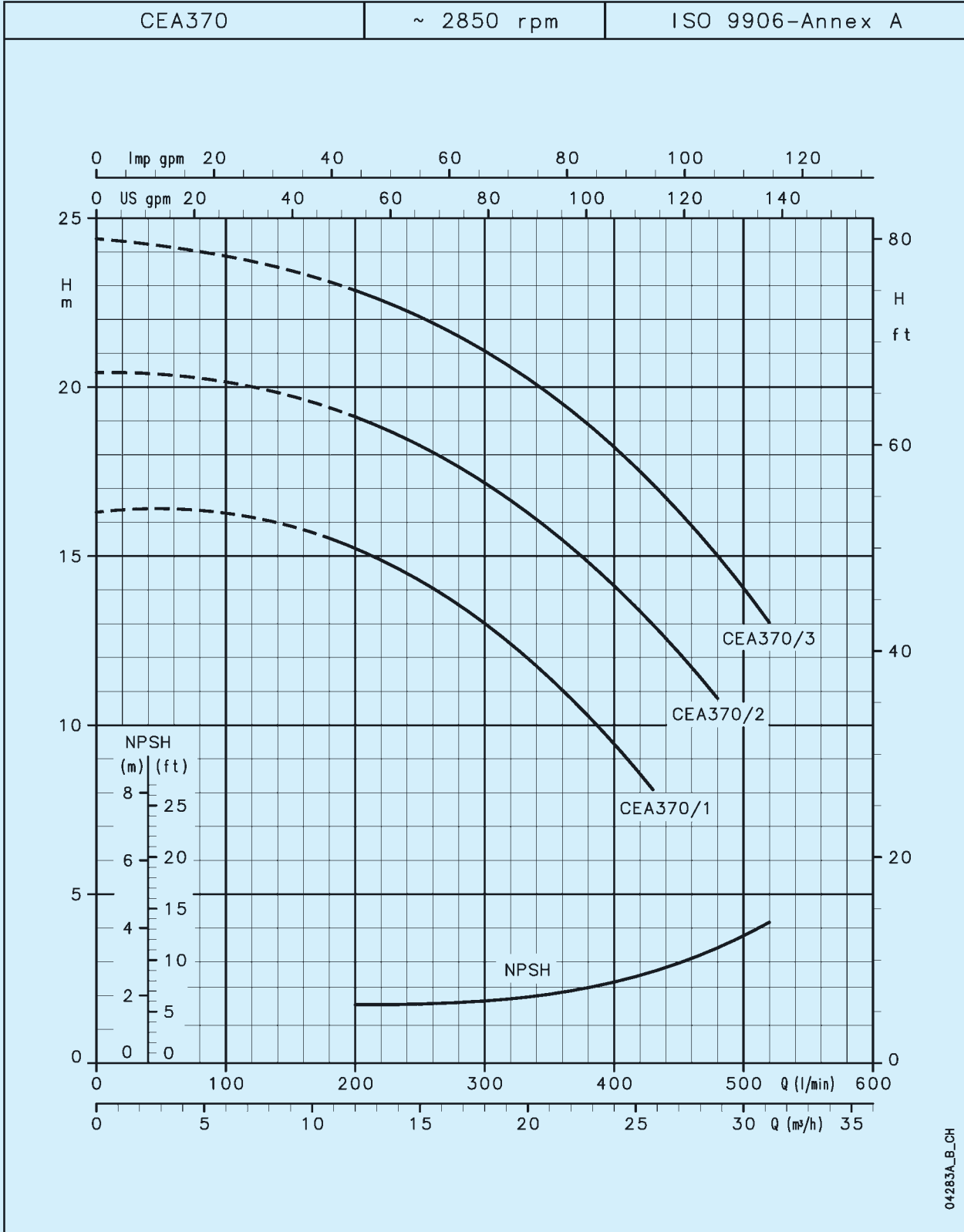

CEA-CA

These performances are valid for liquids with density $\rho = 1.0 \text{ kg/dm}^3$ and kinematic viscosity $\gamma = 1 \text{ mm}^2/\text{sec}$.

**CA70 SERIES
OPERATING CHARACTERISTICS AT 2850 rpm 50 Hz**

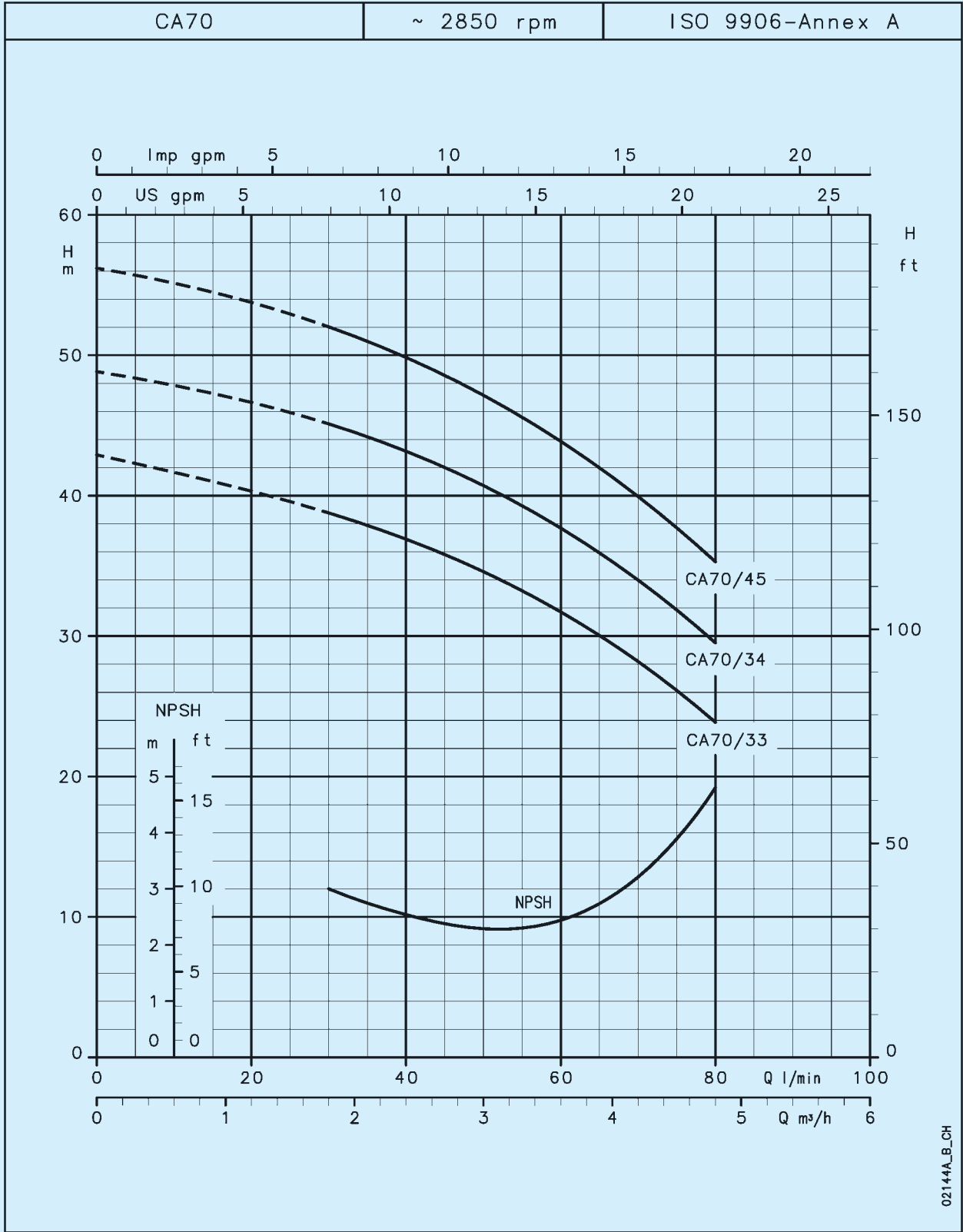

These performances are valid for liquids with density $\rho = 1.0 \text{ kg/dm}^3$ and kinematic viscosity $\gamma = 1 \text{ mm}^2/\text{sec}$.

CEA-CA

02144A_B_CH

**CA120 SERIES
OPERATING CHARACTERISTICS AT 2850 rpm 50 Hz**

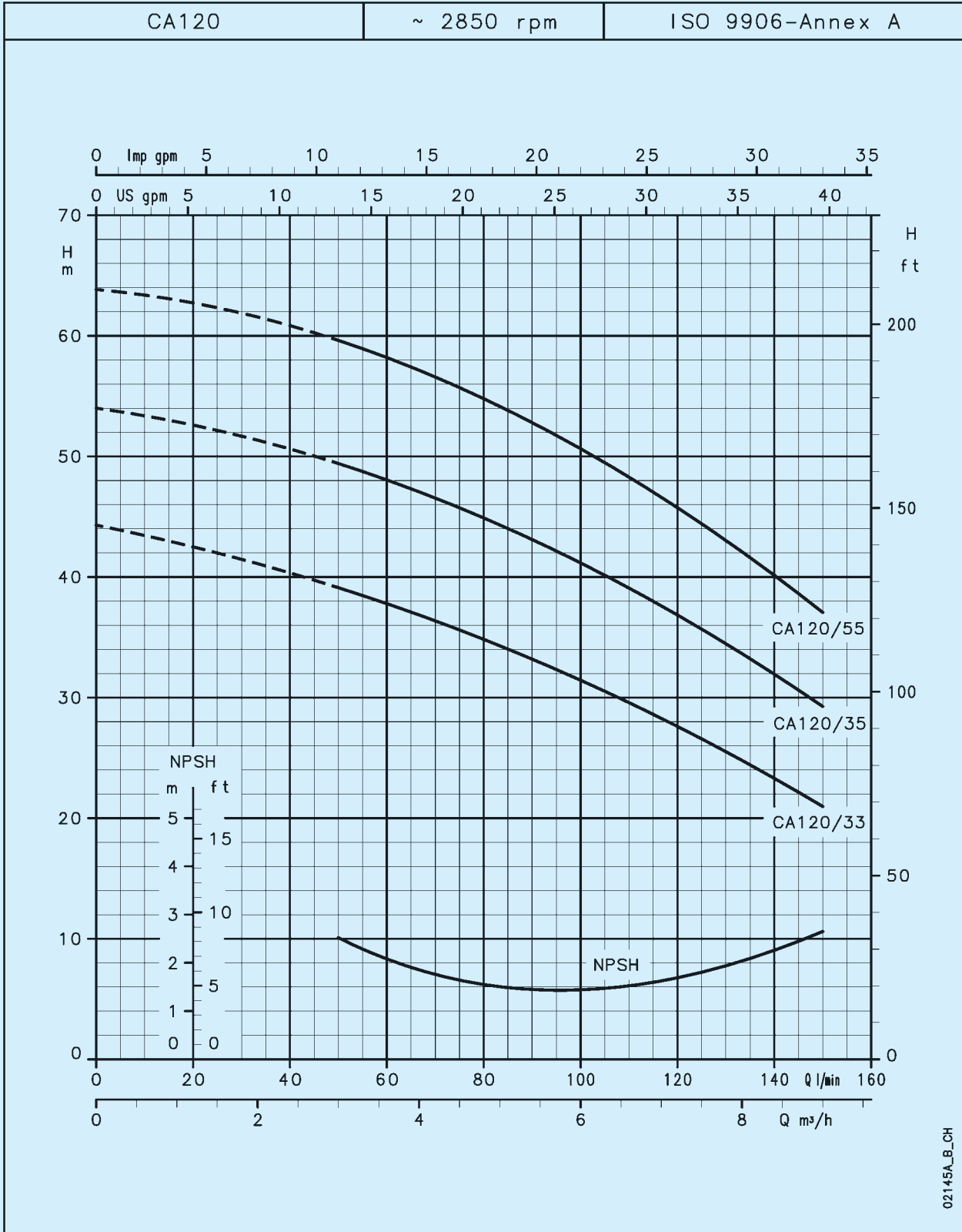

CEA-CA

These performances are valid for liquids with density $\rho = 1.0 \text{ kg/dm}^3$ and kinematic viscosity $\gamma = 1 \text{ mm}^2/\text{sec}$.

**CA200 SERIES
OPERATING CHARACTERISTICS AT 2850 rpm 50 Hz**

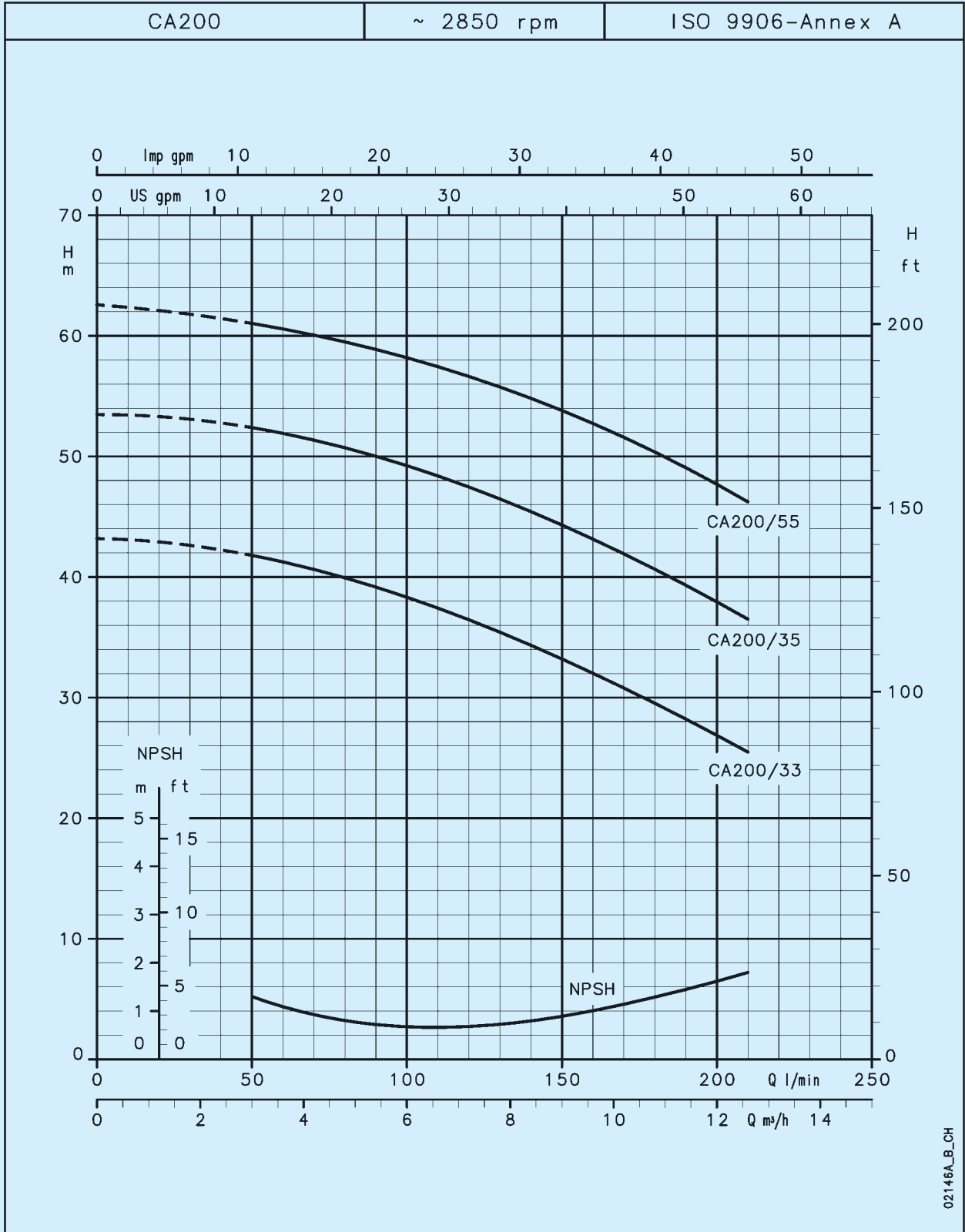

These performances are valid for liquids with density $\rho = 1.0 \text{ kg/dm}^3$ and kinematic viscosity $\gamma = 1 \text{ mm}^2/\text{sec}$.

CEA-CA

02146A_B_CH

DIMENSIONS AND WEIGHTS, CEA SERIES

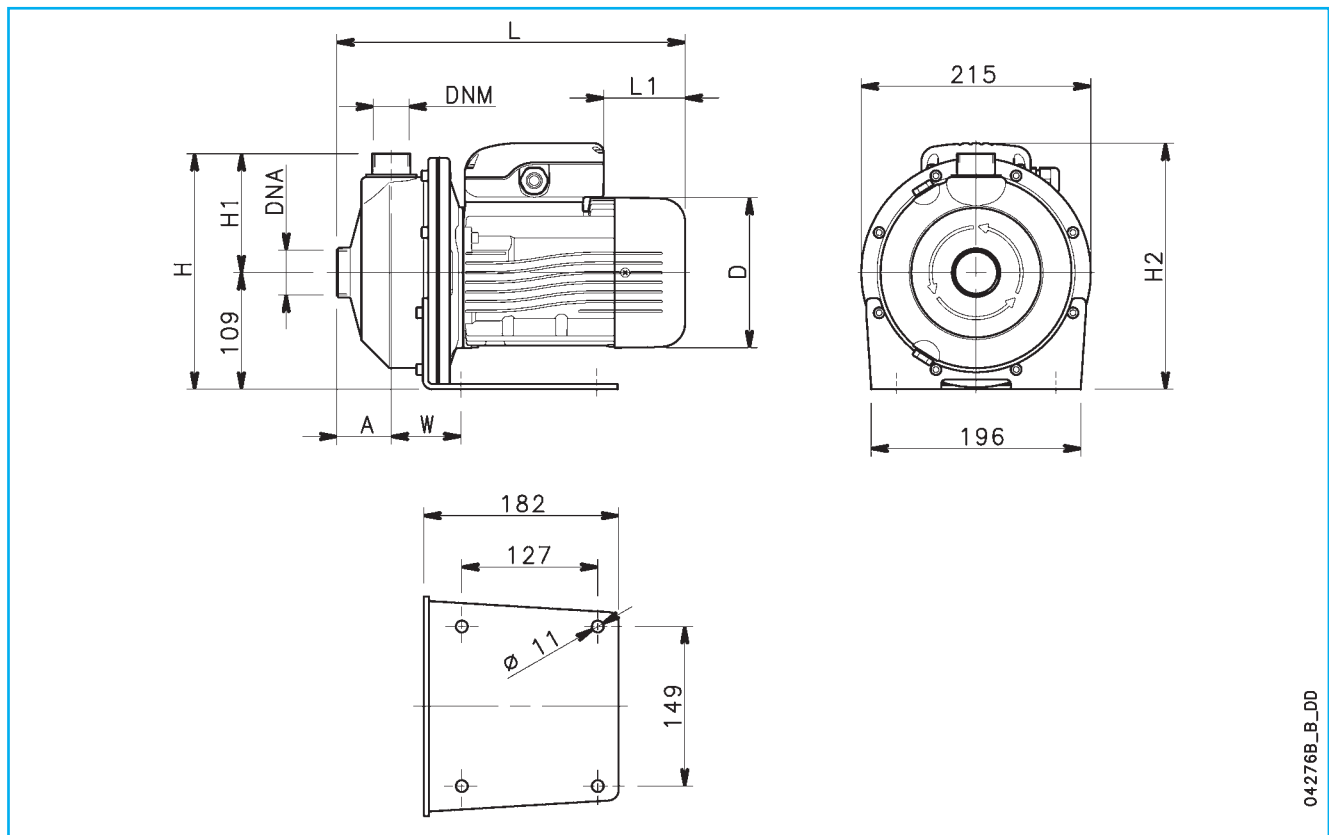

04276B_B_DD

CEA-CA

PUMP TYPE	DIMENSIONS (mm)								DNA	DNM	WEIGHT kg
	A	D	H	H1	H2	L	L1	W			
CEAM 70/3	51	120	220	111	220	311	62	65	Rp 1¼	Rp 1	9.7
CEAM 70/5	51	140	220	111	230	325	76	65	Rp 1¼	Rp 1	11.6
CEAM 80/5	51	140	220	111	230	325	76	65	Rp 1¼	Rp 1	12.5
CEAM 120/3	51	140	220	111	230	325	76	65	Rp 1¼	Rp 1	11.5
CEAM 120/5	51	140	220	111	239	325	31	65	Rp 1¼	Rp 1	13
CEAM 210/2	54	140	222	113	230	339	76	76	Rp 1½	Rp 1¼	13
CEAM 210/3	54	156	222	113	246	385	69	76	Rp 1½	Rp 1¼	14.5
CEAM 210/4	54	156	222	113	246	385	69	76	Rp 1½	Rp 1¼	16.1
CEAM 210/5	54	176	222	113	230	416	114	76	Rp 1½	Rp 1¼	14.4
CEAM 370/1	54	156	222	113	246	385	69	76	Rp 2	Rp 1¼	14
CEAM 370/2	54	156	222	113	246	385	69	76	Rp 2	Rp 1¼	16.1
CEAM 370/3	54	176	222	113	230	416	114	76	Rp 2	Rp 1¼	17.7
CEA 70/3	51	120	220	111	220	311	62	65	Rp 1¼	Rp 1	9.7
CEA 70/5	51	140	220	111	230	325	76	65	Rp 1¼	Rp 1	11.6
CEA 80/5	51	140	220	111	230	325	76	65	Rp 1¼	Rp 1	12.5
CEA 120/3	51	140	220	111	230	325	76	65	Rp 1¼	Rp 1	11.5
CEA 120/5	51	140	220	111	230	325	76	65	Rp 1¼	Rp 1	13
CEA 210/2	54	140	222	113	230	339	76	76	Rp 1½	Rp 1¼	13
CEA 210/3	54	156	222	113	238	385	114	76	Rp 1½	Rp 1¼	14.5
CEA 210/4	54	156	222	113	238	385	114	76	Rp 1½	Rp 1¼	16.1
CEA 210/5	54	156	222	113	238	385	114	76	Rp 1½	Rp 1¼	14.4
CEA 370/1	54	156	222	113	238	285	114	76	Rp 2	Rp 1¼	14
CEA 370/2	54	156	222	113	238	385	114	76	Rp 2	Rp 1¼	16.1
CEA 370/3	54	156	222	113	238	385	114	76	Rp 2	Rp 1¼	17.7

cea-2p50_a_td

DIMENSIONS AND WEIGHTS, CA SERIES

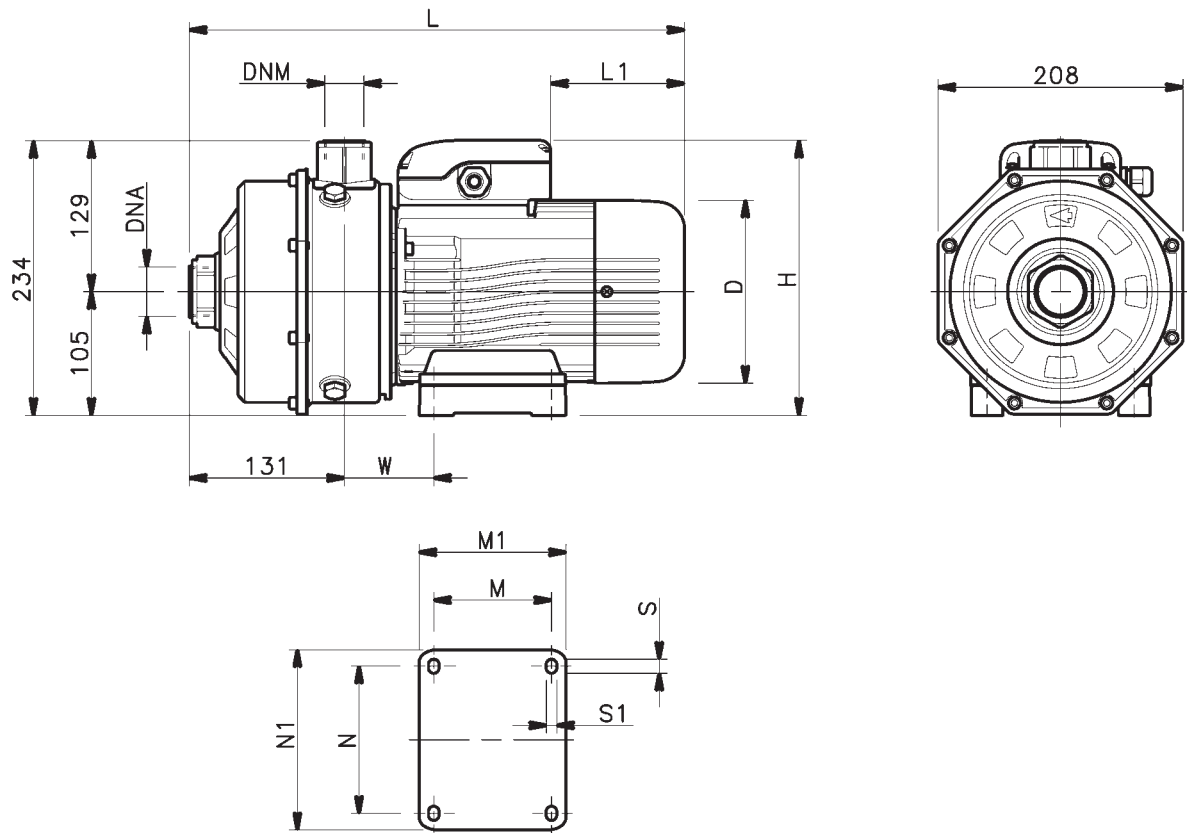

02143B_B_DD

CEA-CA

PUMP TYPE	DIMENSIONS (mm)											DNA	DNM	WEIGHT kg
	D	H	L	L1	M	M1	N	N1	S	S1	W			
CAM 70/33	140	226	383	76	90	113	112	135	12	7	66	Rp 1¼	Rp 1	15
CAM 70/34	140	235	383	31	90	113	112	135	12	7	66	Rp 1¼	Rp 1	15.8
CAM 70/45	156	242	420	69	100	125	125	153	12	9	76	Rp 1¼	Rp 1	18.5
CAM 120/33	156	242	420	69	100	125	125	153	12	9	76	Rp 1¼	Rp 1	18.4
CAM 120/35	156	242	420	69	100	125	125	153	12	9	76	Rp 1¼	Rp 1	20.2
CAM 120/55	176	226	450	114	125	156	140	170	13	9	98	Rp 1¼	Rp 1	24.5
CAM 200/33	176	226	450	114	125	156	140	170	13	9	98	Rp 1½	Rp 1	24.2
CA 70/33	140	226	383	76	90	113	112	135	12	7	66	Rp 1¼	Rp 1	14.9
CA 70/34	140	226	383	76	90	113	112	135	12	7	66	Rp 1¼	Rp 1	15.7
CA 70/35	156	234	420	114	100	125	125	153	12	9	76	Rp 1¼	Rp 1	17
CA 120/33	156	234	420	114	100	125	125	153	12	9	76	Rp 1¼	Rp 1	16.8
CA 120/35	156	234	420	114	100	125	125	153	12	9	76	Rp 1¼	Rp 1	18.7
CA 120/55	156	234	420	114	100	125	125	153	12	9	76	Rp 1¼	Rp 1	20.3
CA 200/33	156	234	420	114	100	125	125	153	12	9	76	Rp 1½	Rp 1	20
CA 200/35	176	226	450	149	125	156	140	170	13	9	98	Rp 1½	Rp 1	22.3
CA 200/55	176	226	450	149	125	156	140	170	13	9	98	Rp 1½	Rp 1	24.3

ca-2p50_a_td