

Self priming electropump made in cast iron suitable domestic pressure boosting, small irrigation, gardening, car washing, tanks and pools emptying and pumping clear water in general.



SPECIFICATIONS

- * Maximum working pressure:
6 bar for JET 60-80-100
10 bar for the other models
- * Maximum liquid temperature:
35°C according EN 60335-2-41 for domestic uses
45°C for other uses
- * Maximum suction: 8 mts

MATERIALS

- * Pump body in cast iron
- * Casing cover in AISI 304 for JET 60-80-100
- * Shaft in AISI 416 for JET 60-80-100
in AISI 303 for the other models

- * Impeller in tecnopolymer for JET 60-80-100
* in brass for the other models
- * Mechanical seal in carbon/ceramic/NBR

TECHNICAL DATA

- * T.E.F.C. 2 poles motor
- * Insulation class F
- * Protection degree IP44 (IP55 on request)
- * 1~230V ± 10% 50Hz, 3~230/400V±10% 50Hz
- * Permanent split capacitor and automatic thermal overload protection for single-phase version
- * Thermal protection to be provided by the user for three-phase version
- * DNM 1"

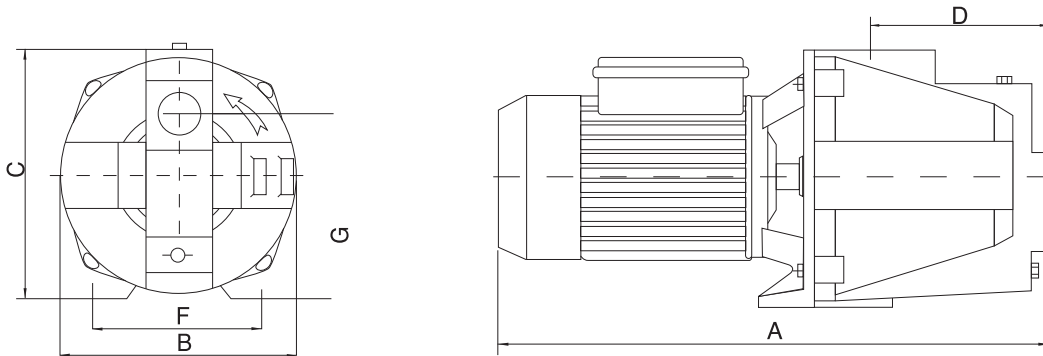

DIMENSIONAL TABLE

TYPE	DIMENSION IN mm.							SUCTION DNA	DISCHARGE DNM	Weight Kg
	A	B	C	D	E	F	G			
JET/60	425	185	210	141	17,5	140	98,5	1"	1"	13
JET/80	425	185	210	141	17,5	140	98,5	1"	1"	14
JET/100	425	185	210	141	17,5	140	98,5	1"	1"	15
JET/150	500	210	225	166	18	166	105	1 1/4"	1"	26
JET/200	500	220	235	57	20	180	110	1 1/2"	1"	27
JET/300	500	220	235	57	20	180	110	1 1/2"	1"	27,5

PERFORMANCE CURVES

(according to ISO 9906 grade 2)

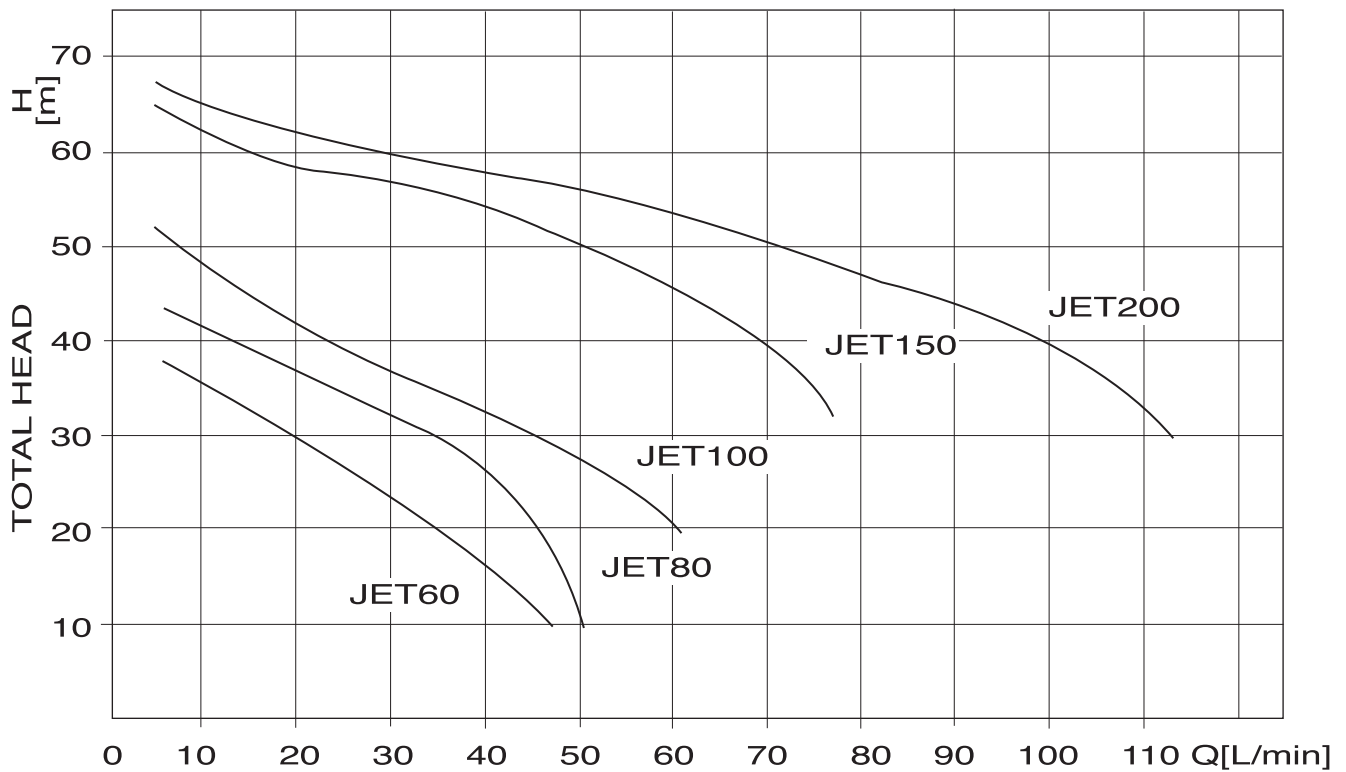

SELECTION TABLE

TYPE	NOMINAL POWER		CAPACITOR MF/450V	ABSORBED CURRENT(A)			Q = Capacity												
	HP	KW		230V-M	230V-T	400V-T	M ³ /H	0,3	0,6	1,2	1,8	2,4	3	3,6	4,8	6	7,2	8,4	9,6
							LT/MIN	5	10	20	30	40	50	60	80	100	120	140	160
JET/60	0.6	0.44	12.5	3,1	2,1	1,2	H = HEAD (MT)	43	38	34	27	22	16						
JET/80	0.75	0.55	14	4,1	2,5	1,5		48	44	40	35	28	23						
JET/100	1	0.74	20	5,3	3,2	2		50	47	43	38	34	30	25					
JET/150	1.5	1.1	31.5	8,5	5,5	3,2		50	48	46	43	40	38	35	32	30			
JET/200	2	1.5	31.5	10,2	6,6	3,8		65	64	61	58	55	51	48	41	35			
JET/300	3	2.2	-	-	8,3	4,9		77	75	71	68	65	61	58	52	45			