



Submersible Sewage Pumps

Channel Impeller

B



Tsurumi B-series, the basic sewage pumps with channel foreign matter-related trouble. Years of know-how are built

Cable Entry

Every cable entry has an anti-wicking block at the cable entry section on the pump. This mechanism is such that a part of each conductor is stripped back and the part is sealed by molded rubber or epoxy potting which has flowed in between each strand of the conductor. This unique feature prevents wicking along the strand of the conductor itself.

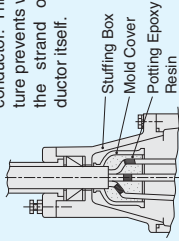

Stuffing Box
Mold Cover
Potting Epoxy
Resin

Motor Protector

Each pump up to 7.5kW as standard has a built-in auto-cut, self-resetting Circle Thermal Protector (CTP). Integrated in the motor housing, the CTP directly cuts the motor circuit if excessive heat builds up or an overcurrent caused by an electrical or mechanical failure occurs.

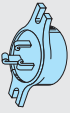

Circle Thermal Protector

A Miniature Thermal Protector (MTP) is embedded in each winding of the motor. These MTPs are connected in series, and their wires are led out of the motor. Should the winding temperature rise to the actuating temperature, the bimetal strip opens to cause the control panel to shut the power supply.



Miniature Thermal Protector

Motor

The motor is a dry-type, squirrel-cage induction motor, housed in a watertight casing, and conforms to insulation classes B, E or F. In each of these insulation classes, all standard pumps can be used in ambient temperatures up to 40°C.

Mechanical Seal

The mechanical seal with two seal faces containing silicon carbide (SiC) is equipped with the oil chamber. The advantages of the seal are two-fold, it eliminates spring failure caused by corrosion, abrasion or fouling which prevents the seal faces from closing properly, and prevents loss of cooling to the lower seal faces during run-dry conditions which causes the lower seal faces to fail.

Oil Lifter (Patentec)

The Oil Lifter was developed as a lubricating device for the mechanical seal. Utilizing the centrifugal force of the shaft seal, the Oil Lifter forcibly supplies lubricating oil to the mechanical seal and continues to supply the oil to the upper seal faces even if lubricant falls below the rated volume. This amazingly simple device is not only reliably lubricates and cools down, but also retains the stable shaft seal effect and extends the inspection term.

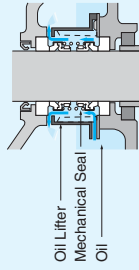

Oil Lifter
Mechanical Seal
Oil

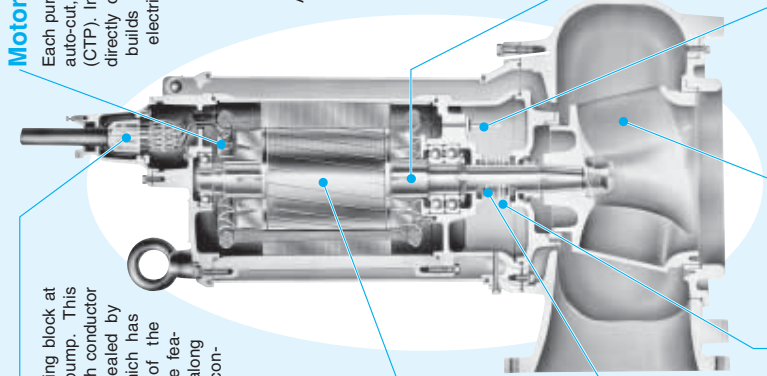

Shaft

The high-tensile stainless steel shaft used on all pumps is designed to have adequate strength for the transmission of the full load. It is supported by C3 type, high-quality, deep-groove ball bearings.

Impeller

The impeller is semi-open or shrouded type with one or two vanes. It has a wide channel extending from inlet to exit, which allows the pump to pass the solid matters from inflow to discharge with minimal blockage.

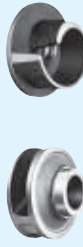

Leakage Sensor

A stainless steel, electrode type leakage sensor is standardized for large pumps of 22kW or over (excluding some models). It senses water incursion into the oil chamber and brings the pump to a halt with the help of a control panel.



MODEL NUMBER DESIGNATION

100 B A 6 3.7 S H

Discharge bore in mm	Sub code for pumping head
Name of the series	H : High head L : Low head
Operation sub code	Phase
None : None automatic operation	None : Three-phase
A : Automatic operation	S : Single-phase
W : Auto-alternation operation	Rated motor output in kW
Number of poles of the motor	

impeller that minimize clogging, winding, and other into very part of the pumps for highly reliable operation.

GUIDE RAIL FITTING SYSTEM

The guide rail fitting system connects the pump to and from the piping easily just by lowering and hoisting the pump, allowing easy maintenance and inspection without the need to enter the sump.

Pump models used in combination with the guide rail fitting system can be identified by the prefix "TOS or TO" and "TS". Refer to standard specifications for availability and model numbers.

TOS and TO

The TOS/TO is the standard guide rail fitting system made of cast-iron and is compatible with cast-iron pumps.



TS

This compact guide rail fitting system is ideal for installing in prefabricated lift stations. Its discharge flange is compatible with major flange standards including ANSI 150lb, BS PN10 and DIN PN10.



DRY PIT MODEL

The advantage of dry pit model is that it will not be damaged by flooding, as it is constructed with a submersible pump.

Tsurumi can provide the dry pit model as an option for the whole range of B-series pumps.

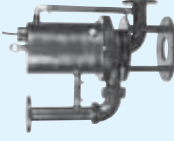

The water jacket covers whole part of the motor. It efficiently cools the motor for continuous operations.

AUTO-ALTERNATION MODEL

The auto-alternation model is used along with an automatic model. The combinational use of these two pumps enables each pump to operate alternately without control panel.

The auto-alternation model has three floats and can be identified by the suffix "W". Refer to standard specifications for availability and model numbers. It is available in the same output range of the automatic pumps.

How the Auto-alternation Model Works

● Operation is enabled by merely connecting the power supply.

Primary Operation

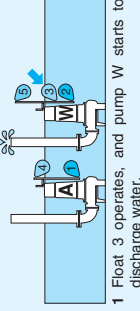

Secondary Operation

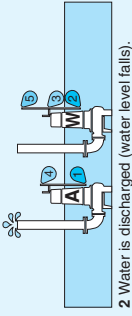
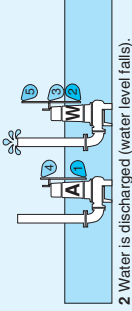
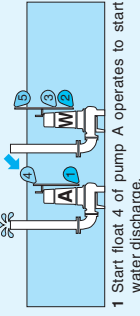

AUTOMATIC MODEL

The automatic model has an integral control circuit and two float switches that operate at a low voltage. It operates automatically in response to the change in water levels. As it has a Circle Thermal Protector (CTP) integrated into the motor to protect the motor from overload or overheating, it is not required to provide an extra motor protection circuit in the starter panel.

This model can be identified by the suffix "A". Refer to the standard specifications for availability and model numbers.

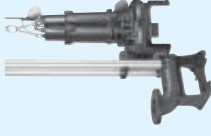

B-series is the Basic of Submersible Sewage Pumps using for all the society fundamentals. Durable and High Quality Products can be used for various kinds of field.

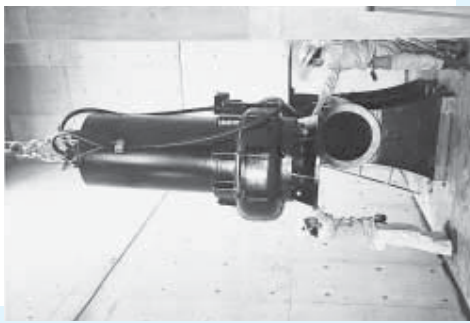

B-series pumps are working in many sewage treatment plants throughout Japan because of their excellent reputations. As durable motor is tough enough against frequent ON/OFF, automatic unattended operation by central control is available.



As it is silent during operation owing to its underwater operation, B-series pumps are often used at the basement of buildings in the city area.

Even if the condition is very severe, sewage pumps are required to have high and steady performance. Tsurumi B-series pumps can give a solution for this problem.



While in overseas, Tsurumi has a lot of sales records with B-series pumps, too. Several inventions adopted by the idea seeking better handling produces ease of maintenance and repair for users comparing to other manufacturers. Because of this, Tsurumi pumps have good reputation as the most intimate pump in the world.



In the shipyard, B-series pumps, which are operated by fully-automatic control, work for level control and dry up. For sea water, sacrificial anodes are applied.



B-series pumps being used for a temporary installation during rainy season. It is used to pump up water of branch river to the main stream when the water level of main stream becomes higher than that of the branch river.

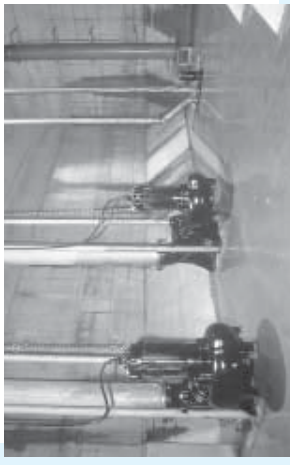

Enough absorption can not be expected in the city center where the ground is covered by concrete. Occasional flood occurs often when a local heavy rain comes. In such case, large capacity B-series pumps play an active role.



Because of its robust construction, B-series pumps are sometimes used for dewatering in construction site. Compact shape allows high portability comparing against the horizontal pump which requires a firm installation foundation work. In such case, some pump parts are changed its material into harder materials.

Dimensions

Free Standing

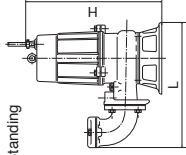

Performance Curves

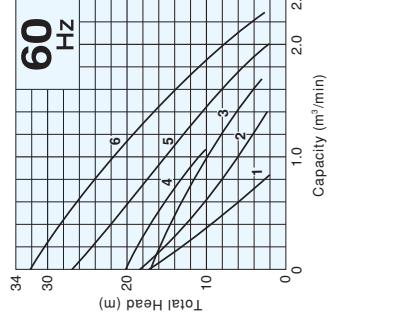
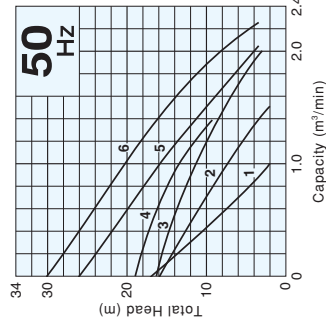
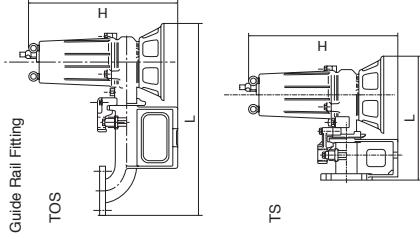
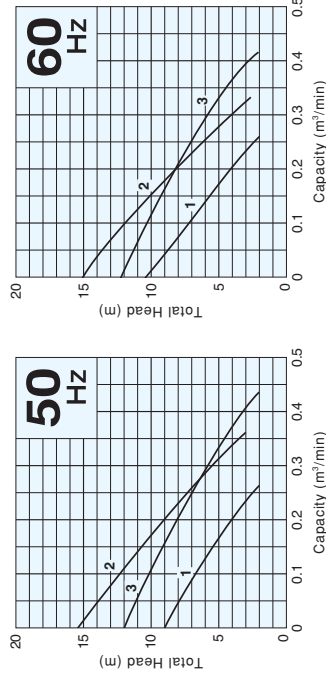

Dimensions

Free Standing



Performance Curves

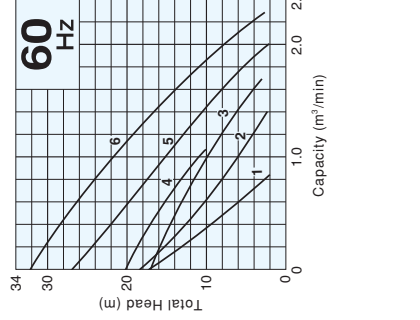
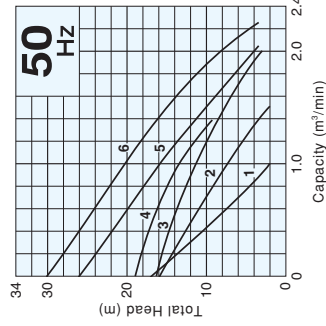
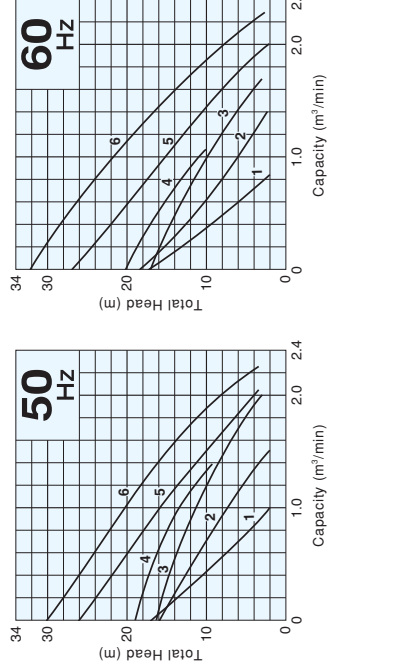

Standard Specifications 50mm

Curve No.	Discharge Bore mm	Standard Model		Automatic Model		Auto-Alternation Model		Motor Output kW	Speed (S.S.) 30Hz/60Hz min ⁻¹	Starting Method	Solids Passage 30Hz/60Hz mm	Cable Length m	Cable Code	Dimensions L × H mm						Dry Weight *3 kg									
		Free Standing	Guide Rail Fitting	Free Standing	Guide Rail Fitting	Free Standing	Guide Rail Fitting							Free Standing	Guide Rail Fitting	Free Standing	Guide Rail Fitting	Free Standing	Guide Rail Fitting	Free Standing	Guide Rail Fitting	Free Standing	Guide Rail Fitting	Free Standing	Guide Rail Fitting				
1	50	50B2.4S	TOS50B2.4S	TS50B2.4S	TS50B2.4S	—	—	—	—	—	—	5	A	340×453	556×511	333×511	—	—	—	—	—	—	—	—	—	25	24	—	—
1	50	50B2.4	TOS50B2.4	TS50B2.4	TS50B2.4	—	—	—	—	—	—	6	A	340×420	556×477	333×477	—	—	—	—	—	—	—	—	—	23	22	—	—
2	50	50B2.75S	TOS50B2.75S	TS50B2.75S	TS50B2.75S	50B2.75S	TOS50B2.75S	TS50B2.75S	—	—	—	5	A(B ^(*))	405×523	621×566	398×566	405×580	621×623	398×623	—	—	—	—	—	—	32	30	34	32
2	50	50B2.75H	TOS50B2.75H	TS50B2.75H	TS50B2.75H	50B2.75H	TOS50B2.75H	TS50B2.75H	—	—	—	6	A	405×415	621×468	398×458	433×468	623×539	403×539	—	—	—	—	—	—	24	23	25	24
3	50	50B2.75	TOS50B2.75	TS50B2.75	TS50B2.75	50B2.75	TOS50B2.75	TS50B2.75	—	—	—	6	A	405×439	621×479	398×479	433×520	623×560	403×560	—	—	—	—	—	—	25	24	26	25

Standard Specifications 80 • 100mm

Curve No.	Discharge Bore mm	Standard Model		Automatic Model		Auto-Alternation Model		Motor Output kW	Speed (S.S.) 30Hz/60Hz min ⁻¹	Starting Method	Solids Passage 30Hz/60Hz mm	Cable Length m	Cable Code	Dimensions L × H mm						Dry Weight *3 kg									
		Free Standing	Guide Rail Fitting	Free Standing	Guide Rail Fitting	Free Standing	Guide Rail Fitting							Free Standing	Guide Rail Fitting	Free Standing	Guide Rail Fitting	Free Standing	Guide Rail Fitting	Free Standing	Guide Rail Fitting	Free Standing	Guide Rail Fitting	Free Standing	Guide Rail Fitting				
1	80	80B21.5	TOS80B21.5	TS80B21.5	TS80B21.5	80B21.5	TOS80B21.5	TS80B21.5	—	—	—	6	A	446×536	668×586	515×586	485×630	707×680	554×680	—	—	—	—	—	—	36	34	40	38
2	100	100B42	TOS100B42	TS100B42	TS100B42	100B42	TOS100B42	TS100B42	—	—	—	6	A(B ^(*))	596×642	754×566	589×631	602×733	780×748	605×748	—	—	—	—	—	—	68	64	78	74
3	100	100B43	TOS100B43	TS100B43	TS100B43	100B43	TOS100B43	TS100B43	—	—	—	6	B(C ^(*))	602×716	760×725	605×700	602×663	760×673	605×674	—	—	—	—	—	—	84	80	94	90
4	100	100B43.7H	TOS100B43.7H	TS100B43.7H	TS100B43.7H	—	—	—	—	—	—	6	B(C ^(*))	603×682	761×706	606×681	—	—	—	—	—	—	—	—	—	82	78	—	—
5	100	100B45	TOS100B45	TS100B45	TS100B45	—	—	—	—	—	—	8	D	687×908	905×906	709×906	—	—	—	—	—	—	—	—	—	147	140	—	—
6	100	100B47.5	TOS100B47.5	TS100B47.5	TS100B47.5	—	—	—	—	—	—	8	E	687×929	905×927	709×927	—	—	—	—	—	—	—	—	—	169	162	—	—

*1 100~120V *2 200~240V

*3 All weights excluding cable

Weights of guide rail fitting model excluding duckfoot bend

Discharge Bore

150 mm

Performance Curves

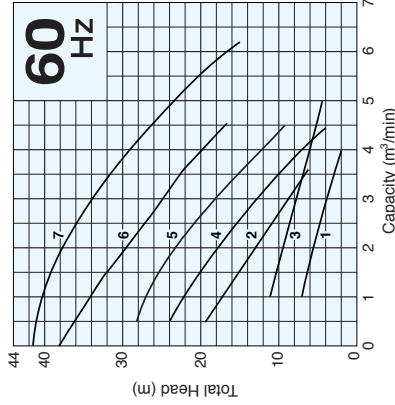
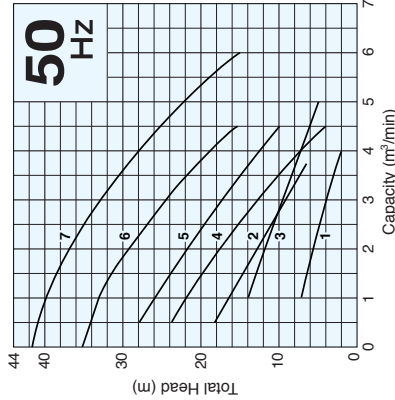

Standard Specifications

Curve No.	Discharge Bore mm	Model		Motor Output kW	Phase	Speed (S.S.) 50Hz/60Hz min ⁻¹	Starting Method	Solids Passage 60Hz/60Hz mm ^{*1}	Cable Length m	Dimensions L x H mm		Dry Weight ^{*3} kg	
		Free Standing	Guide Rail Fitting							Free Standing	Guide Rail Fitting	Free Standing	Guide Rail Fitting
1	150	150B63.7	TOS150B63.7	3.7	Three	1000/1200	D.O.L.	70/55	6	838x903	1023x926	188	158
2	150	150B47.5H	TOS150B47.5H	7.5	Three	1500/1800	D.O.L.	75/70	8	884x952	1028x976	210	180
3	150	150B47.5L	TOS150B47.5L	7.5	Three	1500/1800	D.O.L.	60/50	8	871x1085	1065x1030	200	175
4	150	150B411	TOS150B411	11	Three	1500/1800	Star-Delta	75	8	895x1088	1088x1052	250	220
5	150	150B415	TOS150B415	15	Three	1500/1800	Star-Delta	75	8	895x1168	1089x1122	270	240
6	150	150B422	TOS150B422	22	Three	1500/1800	Star-Delta	75	10	898x1222	1092x1181	327	298
7	150	150B437	TO150B437	37	Three	1500/1800	Star-Delta	40x72/40x50	10	1085x1548	1306x1380	640	540

*1 The solids passage from No.1 to No.6 is described by the sphere diameter that can pass through the impeller.

*2 All weights excluding cable

Weights of guide rail fitting model excluding duckfoot bend

Dimensions

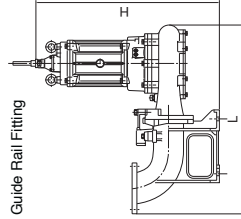
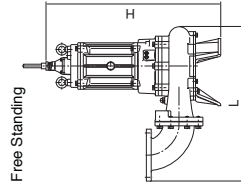

Discharge Bore

200 mm

Performance Curves

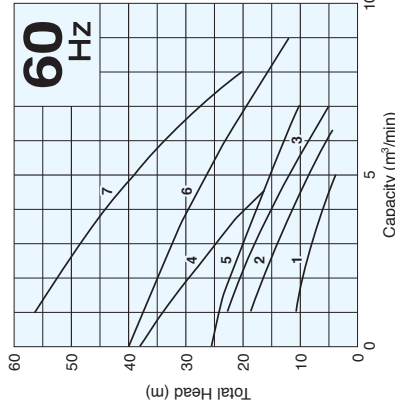
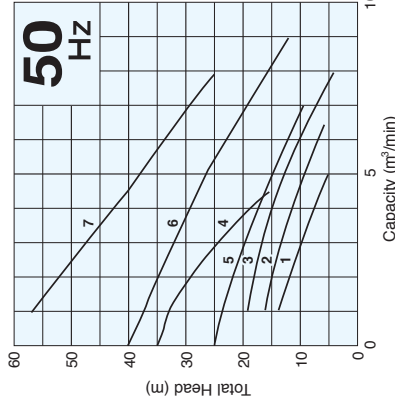

Standard Specifications

Curve No.	Discharge Bore mm	Model		Motor Output kW	Phase	Speed (S.S.) 50Hz/60Hz min ⁻¹	Starting Method	Solids Passage 60Hz/60Hz mm ^{*1}	Cable Length m	Dimensions L x H mm		Dry Weight ^{*3} kg	
		Free Standing	Guide Rail Fitting							Free Standing	Guide Rail Fitting	Free Standing	Guide Rail Fitting
1	200	200B47.5	TO200B47.5	7.5	Three	1500/1800	D.O.L.	80x60/100x50	8	926x1085	1265x1050	207	212
2	200	200B411	TO200B411	11	Three	1500/1800	Star-Delta	68x60/65x58	8	926x1131	1263x1096	258	263
3	200	200B415	TO200B415	15	Three	1500/1800	Star-Delta	70x60/69x60	8	971x1196	1234x1161	300	285
4	200	200B422H	TOS200B422H	22	Three	1500/1800	Star-Delta	75	10	953x1222	1117x1181	332	298
5	200	200B422	TOS200B422	22	Three	1500/1800	Star-Delta	75	10	953x1222	1117x1181	323	289
6	200	200B437	TO200B437	37	Three	1500/1800	Star-Delta	40x77/40x110/45x90	10	1190x1571	1428x1458	670	565
7	200	200B455	TO200B455	55	Three	1500/1800	Star-Delta	45x90	10	1188x1698	1497x1612	1060	1020

*1 The solids passage of No.4 and No.5 is described by the sphere diameter that can pass through the impeller.

*2 200~240V

*3 All weights excluding cable

Weights of guide rail fitting model excluding duckfoot bend

Dimensions

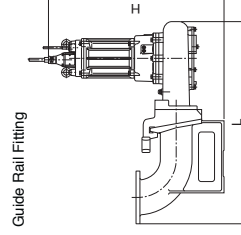
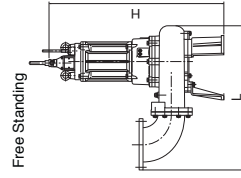

Discharge Bore

250 mm

Performance Curves

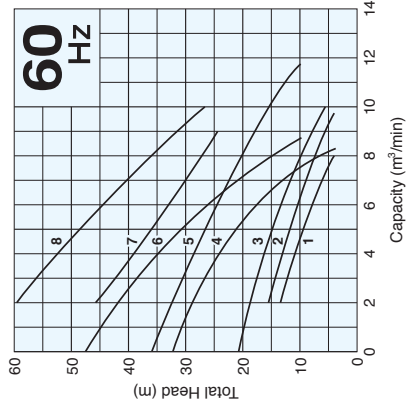
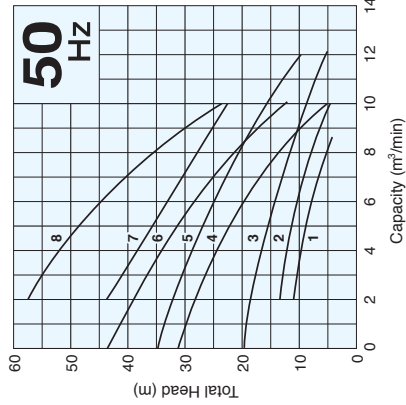

Standard Specifications

Curve No.	Discharge Bore mm	Model		Motor Output kW	Speed (S.S.) 50Hz/60Hz min ⁻¹	Solids Passage 50Hz/60Hz mm ^{*1}	Starting Method Star-Delta	Cable Length m	Cable Code	Dimensions L × H mm		Dry Weight ^{*2} kg	
		Free Standing	Guide Rail Fitting							Free Standing	Guide Rail Fitting	Free Standing	Guide Rail Fitting
1	250	250B611	TO250B611	11	Three	80 × 88/ 80 × 58	Star-Delta	8	M(N ^{*2})	1203 × 1211	513 × 1165	430	390
2	250	250B415	TO250B415	15	Three	79/64	Star-Delta	8	G	1146 × 1228	1451 × 1194	420	380
3	250	250B622	TO250B622	22	Three	90 × 90/ 96 × 76	Star-Delta	10	J	1313 × 1565	1588 × 1504	665	560
4	250	250B430	TO250B430	30	Three	75 × 80/ 76 × 76	Star-Delta	10	J	1295 × 1512	1566 × 1445	645	525
5	250	250B437	TO250B437	37	Three	63 × 80/ 65 × 76	Star-Delta	10	Q	1235 × 1575	1566 × 1508	725	600
6	250	250B445	TO250B445	45	Three	45 × 70/ 45 × 68	Star-Delta	10	J	1313 × 1337	1578 × 1478	695	595
7	250	250B455	TO250B455	55	Three	45 × 70/ 45 × 68	Star-Delta	10	K	1233 × 1888	1586 × 1635	1100	1040
8	250	250B475	TO250B475	75	Three	35 × 75/ 35 × 78	Star-Delta	10	K	1233 × 1888	1586 × 1635	1150	1090

^{*1} The solids passage of No.2 is described by the sphere diameter that can pass through the impeller.

^{*2} 200~240V

^{*3} All weights excluding cable

Weights of guide rail fitting model excluding duckfoot bend

Dimensions

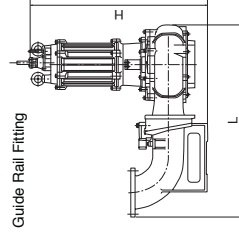
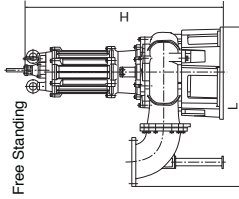

9

Performance Curves

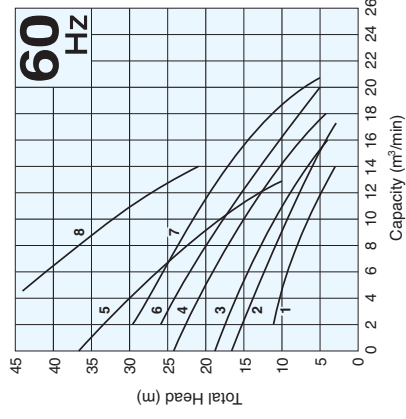
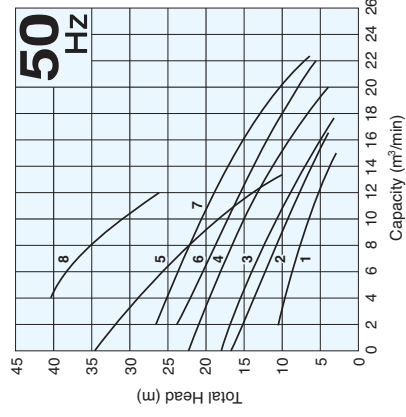

Standard Specifications

Curve No.	Discharge Bore mm	Model		Motor Output kW	Speed (S.S.) 50Hz/60Hz min ⁻¹	Starting Method Star-Delta	Solids Passage 50Hz/60Hz mm	Cable Length m	Cable Code	Dimensions L × H mm		Dry Weight ^{*2} kg		
		Free Standing	Guide Rail Fitting							Free Standing	Guide Rail Fitting	Free Standing	Guide Rail Fitting	
1	300	300B615	TO300B615	15	Three	1000/1200	Star-Delta	140 × 60/ 140 × 60	8	N(O ^{*1})	1302 × 1314	1686 × 1274	550	520
2	300	300B622	TO300B622	22	Three	1000/1200	Star-Delta	140 × 76/ 127 × 76	10	J	1386 × 1574	1685 × 1577	720	615
3	300	300B630	TO300B630	30	Three	1000/1200	Star-Delta	130 × 115/ 140 × 76	10	Q	1366 × 1637	1685 × 1640	765	635
4	300	300B637	TO300B637	37	Three	1000/1200	Star-Delta	140 × 100/ 140 × 65	10	Q	1386 × 1644	1685 × 1647	785	660
5	300	300B445	TO300B445	45	Three	1500/1800	Star-Delta	60 × 90/ 70 × 76	10	J	1348 × 1586	1667 × 1567	785	655
6	300	300B645	TO300B645	45	Three	1000/1200	Star-Delta	130 × 85/ 134 × 76	10	K	1414 × 1788	1778 × 1721	1300	1230
7	300	300B655	TO300B655	55	Three	1000/1200	Star-Delta	105 × 90/ 110 × 90	10	K	1414 × 1833	1778 × 1766	1550	1500
8	300	300B475	TO300B475	75	Three	1500/1800	Star-Delta	65 × 80/ 65 × 90	10	K	1436 × 1688	1795 × 1663	1150	1100

^{*1} 200~240V

^{*2} All weights excluding cable

Weights of guide rail fitting model excluding duckfoot bend

Dimensions

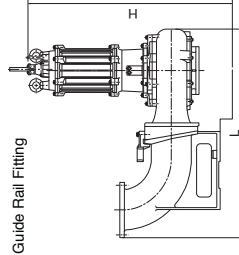
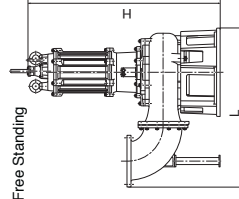

10

Discharge Bore

350 mm

Performance Curves

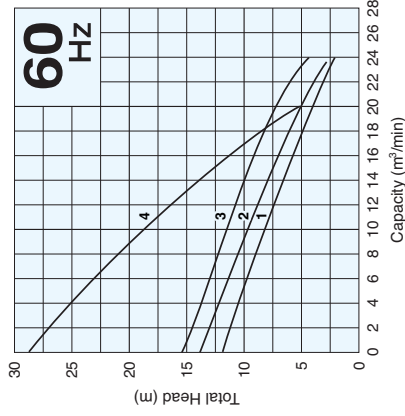
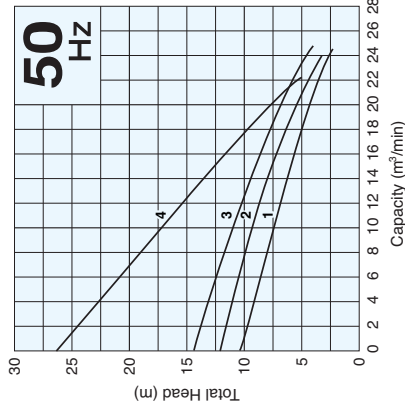

Standard Specifications

Curve No.	Discharge Bore mm	Model		Motor Output kW	Speed (S.S.) 50Hz/60Hz min ⁻¹	Starting Method	Solids Passage 50Hz/60Hz mm	Cable Length m	Cable Code	Dimensions L × H mm		Dry Weight *2 kg	
		Free Standing	Guide Rail Fitting							Free Standing	Guide Rail Fitting	Free Standing	Guide Rail Fitting
1	350	350B822	TO350B822	22	750/900	Star-Delta	156 × 100 / 160 × 90	10	J	1488 × 1677	1845 × 1692	910	760
2	350	350B630	TO350B630	30	1000/1200	Star-Delta	190 × 95 / 200 × 70	10	J(Q*)	1488 × 1677	1845 × 1692	870	720
3	350	350B637	TO350B637	37	1000/1200	Star-Delta	190 × 130 / 200 × 100	10	J(Q*)	1488 × 1684	1845 × 1699	905	750
4	350	350B645	TO350B645	45	1000/1200	Star-Delta	130 × 90 / 140 × 78	10	J	1508 × 1788	1845 × 1811	1316	1161

*1 200~240V

*2 All weights excluding cable

Weights of guide rail fitting model excluding duckfoot bend

Dimensions

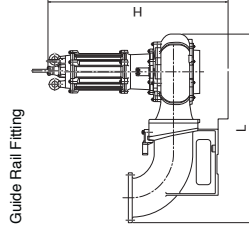
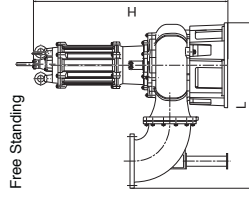

Discharge Bore

400 mm

Performance Curves

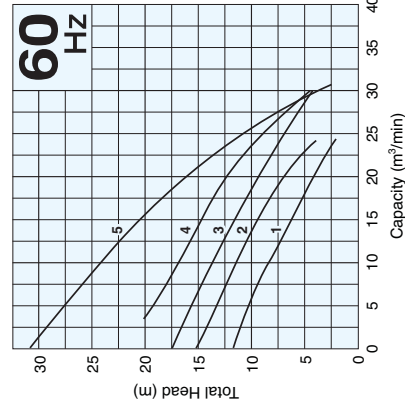
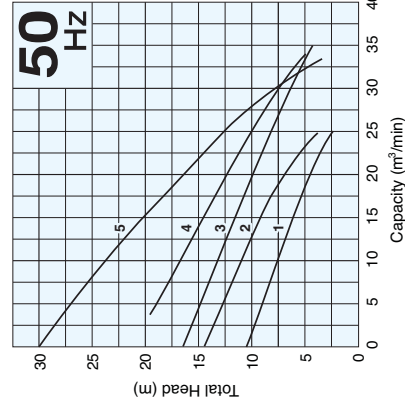

Standard Specifications

Curve No.	Discharge Bore mm	Model		Motor Output kW	Speed (S.S.) 50Hz/60Hz min ⁻¹	Starting Method	Solids Passage 50Hz/60Hz mm	Cable Length m	Cable Code	Dimensions L × H mm		Dry Weight *2 kg	
		Free Standing	Guide Rail Fitting							Free Standing	Guide Rail Fitting	Free Standing	Guide Rail Fitting
1	400	400B822	TO400B822	22	750/900	Star-Delta	156 × 109 / 160 × 90	10	J	1583 × 1677	2122 × 1752	930	865
2	400	400B637	TO400B637	37	1000/1200	Star-Delta	190 × 130 / 200 × 100	10	J(Q*)	1583 × 1684	2122 × 1759	925	855
3	400	400B645	TO400B645	45	1000/1200	Star-Delta	175 × 128 / 175 × 100	10	J	1633 × 1792	2130 × 1920	1416	1346
4	400	400B655	TO400B655	55	1000/1200	Star-Delta	145 × 110 / 175 × 100	10	K	1621 × 1878	2141 × 1956	1750	1700
5	400	400B675	TO400B675	75	1000/1200	Star-Delta	130 × 100 / 140 × 90	10	K	1616 × 1878	2136 × 1956	1850	1800

*1 200~240V

*2 All weights excluding cable

Weights of guide rail fitting model excluding duckfoot bend

Dimensions

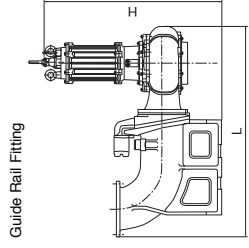
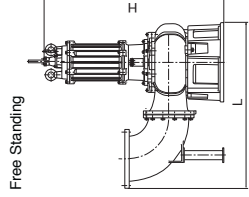

Discharge Bore

500 mm

Performance Curves

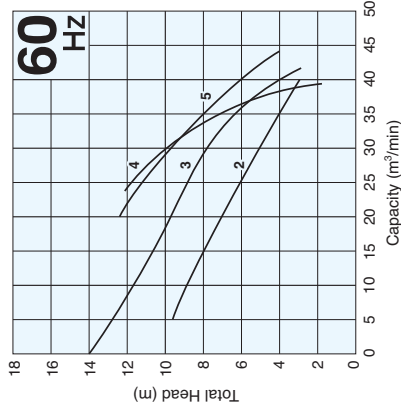
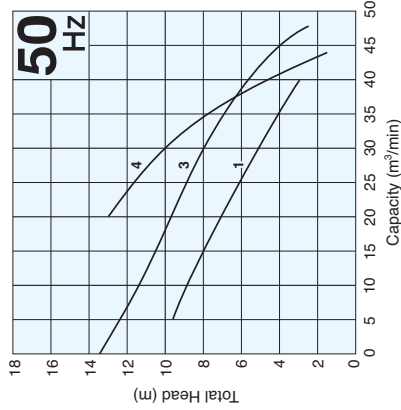

Standard Specifications

Curve No.	Discharge Bore mm	Model		Motor Output kW	Speed (SS) 50Hz/60Hz min ⁻¹	Solids Passage Method	Cable Length m	Dimensions L x H mm		Dry Weight* kg		Frequency
		Free Standing	Guide Rail Fitting					Free Standing	Guide Rail Fitting			
1	500	500B1037	TO500B1037	37	600	Star-Delta	10	2073x201	2822x2183	2050	1950	50Hz only
2	500	500B1237	TO500B1237	37	600	Star-Delta	10	2073x201	2822x2183	2050	1950	60Hz only
3	500	500B855	TO500B855	55	750/900	Star-Delta	10	2111x207	2860x2225	2150	2050	50Hz/60Hz
4	500	500B675	TO500B675	75	1000/1200	Star-Delta	10	2283x187	2812x2152	2150	2050	50Hz/60Hz
5	500	500B875	TO500B875	75	900	Star-Delta	10	2150x204	2700x284	2550	2450	60Hz only

* All weights excluding cable
Weights of guide rail fitting model excluding duckfoot bend

Dimensions

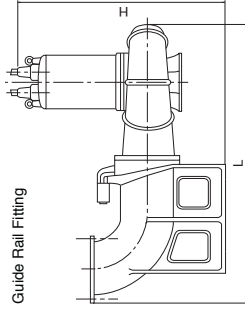
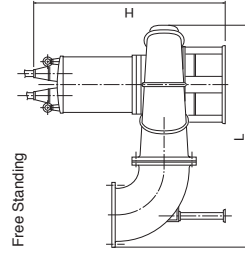

Discharge Bore

600 • 700 • 800 mm

Performance Curves

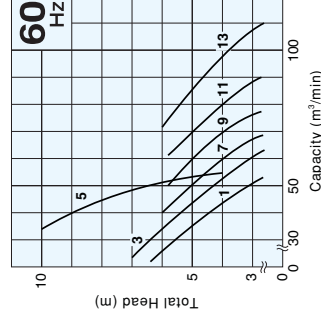
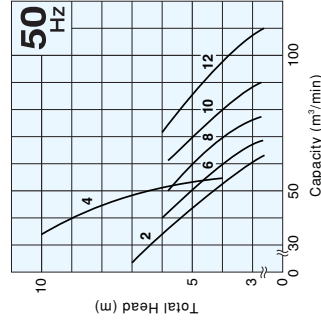

Standard Specifications

Curve No.	Discharge Bore mm	Model		Motor Output kW	Speed (SS) 50Hz/60Hz min ⁻¹	Starting Method	Solids Passage mm	Cable Length m	Cable Code	Dimensions L x H mm		Dry Weight* kg		Frequency
		Free Standing	Guide Rail Fitting							Free Standing	Guide Rail Fitting			
1	600	600B1845	TO600B1845	45	Three	Star-Delta	280 x 90	10	K	2822x3100	3082x3100	5000	5200	60Hz only
2	600	600B1255	TO600B1255	55	Three	Star-Delta	220 x 100	10	K	2822x3100	3082x3100	3150	3350	50Hz only
3	600	600B1455	TO600B1455	55	Three	Star-Delta	220 x 100	10	K	2822x3100	3082x3100	3150	3350	60Hz only
4	600	600B1085	TO600B1085	85	Three	Star-Delta	210 x 85	10	K	2468x3100	3008x3100	3100	3300	50Hz only
5	600	600B1285	TO600B1285	85	Three	Star-Delta	210 x 85	10	K	2468x3100	3008x3100	3100	3300	60Hz only
6	700	700B1265	TO700B1265	65	Three	Star-Delta	300 x 85	10	K	2840x3560	3440x3660	4000	4400	50Hz only
7	700	700B1465	TO700B1465	65	Three	Star-Delta	300 x 85	10	K	2840x3560	3440x3660	4000	4400	60Hz only
8	700	700B1275	TO700B1275	75	Three	Star-Delta	300 x 85	10	K	2840x3560	3440x3660	4200	4600	50Hz only
9	700	700B1475	TO700B1475	75	Three	Star-Delta	300 x 85	10	K	2840x3560	3440x3660	4200	4600	60Hz only
10	800	800B1290	TO800B1290	90	Three	Star-Delta	300 x 90	10	L	3653x3790	3623x3790	5600	5800	50Hz only
11	800	800B1490	TO800B1490	90	Three	Star-Delta	300 x 90	10	L	3653x3790	3623x3790	5600	5800	60Hz only
12	800	800B1410	TO800B1410	110	Three	Star-Delta	310 x 90	10	L	3653x3790	3623x3790	5800	6000	50Hz only
13	800	800B1610	TO800B1610	110	Three	Star-Delta	310 x 90	10	L	3653x3790	3623x3790	5800	6000	60Hz only

* All weights excluding cable
Weights of guide rail fitting model excluding duckfoot bend

Dimensions

Free Standing

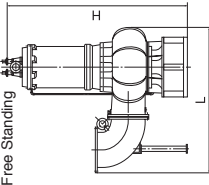

Guide Rail Fitting

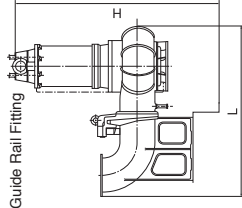

CABTYRE CABLE CODE REFERENCE

Single-phase

Code	No. of Cables	Cores × mm ²	Outer Dia. mm	Material
a	1	3 × 1.25	10.1	PVC
b	1	3 × 2.0	10.9	

Code	No. of Cables	Cores × mm ²	Outer Dia. mm	Material
D	1	4 × 3.5	14.1	Chloroprene Rubber
E	1	4 × 5.5	16.8	
F	3	4 × 3.5	14.1	
		3 × 3.5	12.9	
		2 × 1.25	9.8	
G	3	4 × 5.5	16.8	
		3 × 5.5	15.2	
		2 × 1.25	9.8	
J	3	4 × 14	21.7	Chloroprene Rubber
		3 × 14	19.7	PVC
		4 × 1.25	11.1	
K	2	3 × 38	35.8	Chloroprene Rubber
		1 × 22		
		3 × 2		
		3 × 38		

Code	No. of Cables	Cores × mm ²	Outer Dia. mm	Material	
L	2	3 × 60	45.7	Chloroprene Rubber	
		1 × 22			
		3 × 2			
M	1	7 × 3.5	21.3		
		2 × 2			
N	1	7 × 5.5	24.4		
O	1	7 × 8	25.6		
		2 × 2			
P	3	4 × 14	21.7		Chloroprene Rubber
		3 × 14	19.7		PVC
		2 × 1.25	9.6		
Q	3	4 × 22	28.8	Chloroprene Rubber	
		3 × 22	26.1	PVC	
		4 × 1.25	11.1		

Three-phase

Code	No. of Cables	Cores × mm ²	Outer Dia. mm	Material
A	1	4 × 1.25	11.1	PVC
B	1	4 × 2.0	11.8	
C	1	4 × 3.5	13.9	

TSURUMI OPTIONS

SPECIAL VERSION WITH GALVANIC CORROSION PROTECTION

In seawater, a material's resistance to corrosion can be seen clearly. When metals with different potentials are brought into contact in seawater, only the metal of lower potential corrodes. As the difference in potential increases, the metal of lower potential corrodes faster. As an option, Tsurumi can supply pumps with parts made of higher electric potential metal as the sacrificial anode.

SPECIAL VERSION FOR HIGHER TEMPERATURE LIQUID

Standard pumps are designed for continuous running at the maximum ambient temperature of 40°C. In addition to these, Tsurumi can provide pumps for operation at higher liquid temperatures upon request. Refitting for operation at higher temperatures involves modification of not only the insulation of motor windings but also several components.

Two high-temperature operating models are available - the Rank 60 for operation in liquids up to 60°C and the Rank 90 for operation in liquids up to 90°C. Consult your dealer for more details. (These special versions are not available for some pump models.)

SPECIAL VERSION WITH NON-STANDARD MATERIALS

Tsurumi can also provide you with pumps with essential components such as the impeller, pump casing and the suction cover made of non-standard materials. Select from stainless steel, chromium iron and bronze to suit your specific requirements. Consult your dealer for more details.

SPECIAL ACCESSORIES

FLOAT SWITCHES

Tsurumi offers two types of float switches (liquid level sensors). A micro-switch is incorporated in both types.

Model MC-2 is a heavy-duty type float switch with a shock absorber. Having equipped with a high grade micro switch, the MC-2 assures trouble-free operation in the liquid containing much suspended solids and floating scum. Either of the two contacts, normally-open or normally-close, can be selected as required.

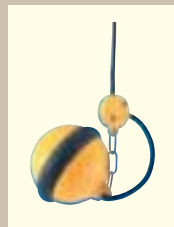

Model RF-5 is an economy type float which can detect upper/lower-limit water levels with single float. The snap on-off action ensures stable operation in clean or waste water containing suspended solids or oil and fat.



We reserve the right to change the specifications and designs for improvement without prior notice.

TSURUMI
MANUFACTURING CO., LTD.

Your Dealer